



# Wall Cladding Installation Guide

v05 AUS

**Note:** This Installation Guide applies to both Shadowline and Shou Sugi Ban boards.



# CONTENTS

Important Note	3 - 5
Cladding Parts	6 - 9
Under Construction	10
Battens Installation	11
Expansion and Contraction Values	12
Locking The Wall Cladding Board Wall	13 - 16
Cladding-Horizontal Installation	17
-Framing	18 - 20
-Install the Trim Bases	21
-Install the First board	22 - 26
-Install the Second course	27 - 28
-Install the Last Cladding board	28 - 30
-Install the Trim Covers	30 - 31
-Butt Joint Installation	31-33
Wall Cladding-Vertical Installation	34
-Framing	35 - 37
-Install the Trim Bases	38
-Install the First board	39 - 41
-Install the Second Board	41 - 42
-Install the Last Cladding Board	42 - 45
-Install the Trim Covers	46
-Butt Joist Installation	47 - 48

## IMPORTANT:

# Read All Sections Before You Start

For the most up to date information, please visit our website @ <http://newtechwood.com.au>

Prior to installing any composite cladding system, it is recommended that you check with local building codes for any special requirements or restrictions. The diagrams and instructions outlined in this guide are for illustration purposes only and are not meant or implied to replace a licensed professional. Any construction or use of NewTechWood must be in accordance with all local zoning and/or building codes. The consumer assumes all risks and liability associated with the construction and use of this product.

## Safety

When dealing with any type of construction project, it is necessary to wear appropriate safety equipment to avoid any risk of injuries. NewTechWood recommends, but is not limited to the following safety equipment, when handling, cutting, and installing NewTechWood: gloves, a respiratory protection, long sleeves, pants, and safety glasses.

## Tools

Standard woodworking tools may be used. It is recommended that all blades have a carbide tip. Standard stainless steel or acceptable coated deck screws and nails are recommended.

## Environment

A clean, smooth, flat, and strong surface is needed to install NewTechWood's products correctly. Please check with local building codes before ever installing any type of cladding. If installation does not occur immediately, NewTechWood's products need to be put on a flat surface at all times. It should NEVER be put on a surface that is NOT flat.

## Planning

Plan a layout for your cladding before starting it to ensure the best possible looking cladding for your project. Building codes and zoning ordinances generally apply to permanent structures, meaning anything that is anchored to the ground or attached to the house. So nearly every kind of cladding requires permits and inspections from a local building department. We recommend drawing out a site plan of your proposed project that you intend to do to minimize errors and make your perfect wall cladding.

**Pressure washing on a scrap piece of material before using a pressure washer on the wall cladding to ensure that your settings will not damage the Ultrashield coating.**

## Construction

NewTechWood UltraShield is NOT intended for use as columns, support posts, beams, joist stringers, support against a force, or other primary load-bearing members. NewTechWood must be supported by a code-compliant substructure. While NewTechWood products are great for retrofits, NewTechWood's products CANNOT be installed on existing cladding boards.

## Static

Static can also be more prevalent in areas that are of higher altitude because the humidity is lower. For these areas, be careful of using conducive objects such as metal railing and chairs as static shocks might occur more often. A potential way to lower the amount of static shocks occurring is to apply Staticide ([www.aclstaticide.com](http://www.aclstaticide.com)) on your deck or use anti-static mats before doorways.

## Ventilation

NewTechWood products CANNOT be directly installed onto a flat surface. It must be installed onto a substructure, so there is adequate and unobstructed air flow under the cladding to prevent excessive water absorption. A minimum of 25 mm of continuous net free area under the cladding surface is required for adequate ventilation on all cladding, so air can circulate between adjacent members to promote drainage and drying.

## Heat and Fire

Excessive heat on the surface of NewTechWood products from external sources such as but not limited to fire or reflection of sunlight from energy efficient window products. Low-emissivity (Low-E) glass can potentially harm NewTechWood products. Low-E glass is designed to prevent passive heat gain within a structure and can cause unusual heat build-up on exterior surfaces. This extreme elevation of surface temperatures, which exceeds that of normal exposure, can possibly cause NewTechWood products to melt, sag, warp, discolor, increase expansion/contraction, and accelerate weathering.

Current or potential NewTechWood customers that have concerns about possible damage by Low-E glass should contact the manufacturer of the product, which contains Low-E glass for a solution to reduce or eliminate the effects of reflected sunlight.

## Fasteners

When fastening NewTechWood's products all screws that are face fastened should always be driven in at a 90 degree angle to the cladding surface. Toe screwing should never be done to the products. An extra joist should be added if a 90 degree angle cannot be driven into the board. All fasteners should be on their own independent joists, when two boards ends meet each other there must be a sister batten. The end of each board must sit on its own batten.

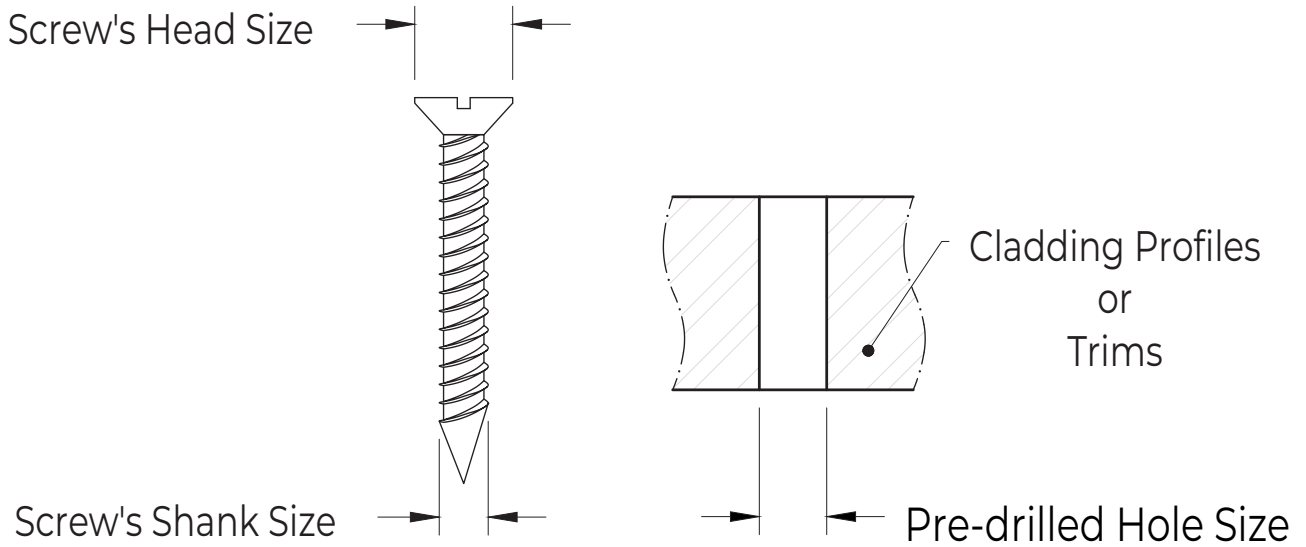
Use white chalk, straight boards, or string lines as templates for straight lines. NEVER USE COLORED CHALK. Colored chalk will permanently stain NewTechWood's products and are highly not recommended.

All screws that are face fixed should always be stainless steel. Depending on the screws that you use when face fixing, there could be potential bulging or mushrooming. It is recommended to take care of these mushrooms/bulges by taking a rubber mallet and patting them down to give your cladding a better look.

When choosing which screws to use always check first with your local home centers and hardware stores to see if they have screws that are engineered specifically for composite wood. These screws will always work and give NewTechWood's products the best looking outcome, using other screws that are not recommended for composite could potentially damage/harm the cladding. If you are unsure which screw to use, contact your manufacturer for more information.

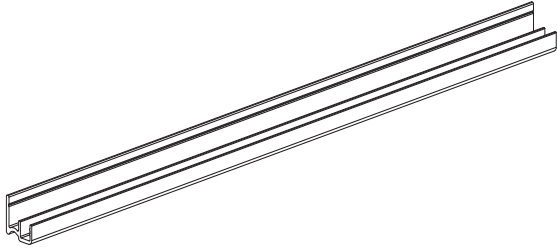
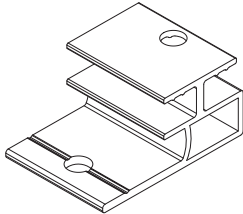
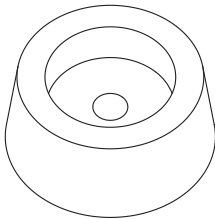
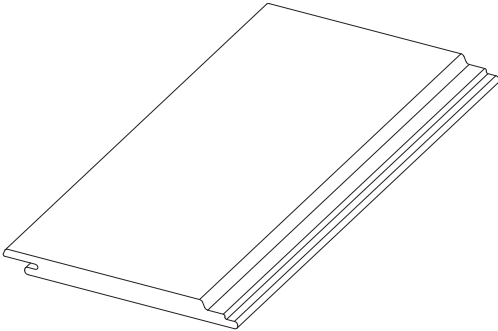
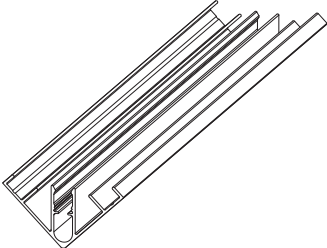
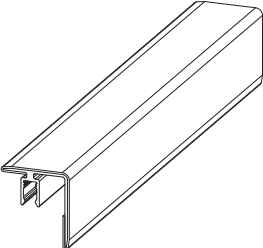
## Predrill

When face fixing, it is recommended to predrill the holes slightly larger than the screw's shank size on the cladding profiles and the trims to allow for expansion and contraction response to temperature change, as shown in below diagram,



Moreover, the predrilled hole size should also be smaller than the screw head size.


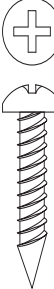


## Wall Cladding Parts

Model no.	Purpose	Picture
AW-02	Starter Profile, used for the installation of the first board	
AW-08	Clip, used at every batten to fix each board to the batten	
T-7	Used on the last wall cladding board	
US31/ US31SS	Wall Cladding Board Shadowline or Shou Sugi Ban or (US31, US31SS)	
AA44	Aluminum End Trim Base. Used at the Outermost Edge	
CA48	Aluminum End Trim Cover. Used at the Outermost Edge	

## Wall Cladding Parts

Model no.	Purpose	Picture
AA46	Aluminum Inside Corner Trim Base Used at the Inside Corner	
CA50	Aluminum Inside Corner Trim Cover Used at the Inside Corner	
AA47	Aluminum Outside Corner Trim Base Used at the Outside Corner	
CA51	Aluminum Outside Corner Trim Cover Used at the Outside Corner	
AA45	Butt Joist Trim, used at the outermost wall edge	
CA49	Butt Joist Cover used if there is a break between two boards to cover up the gap.	


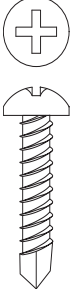

# Wall Cladding Screws (For Timber Battens)

Product	Purpose	Part
<p><b>*M3 x 12</b>  <b>SS304. Part</b>  <b>code: WJ063</b></p>	<p>Used when locking the board into AW08 (Screws supplied by NTW)</p>	
<p><b>*8G x 20</b>  <b>SS304</b>  <b>(Pan Head)</b></p>	<p>Used when installing AW08 into timber battens            (Screws not included, sourced / supplied by builder/installer)</p>	
<p><b>*8G x 20</b>  <b>SS304</b>  <b>(Flat Head)</b></p>	<p>Used when installing trims into timber battens            (Screws not included, sourced / supplied by builder/installer)</p>	
<p><b>*8G x 50</b>  <b>SS304</b>  <b>(Colour Head Composite Screw)</b></p>	<p>Used for face fixing the first and last boards next to trims            (Screws supplied by NTW)</p>	



# Wall Cladding Screws (For Metal/Aluminum Battens)

NOTE: This Installation Guide is suitable for Installation of Shadowline boards and Shou Sugi Ban Boards.

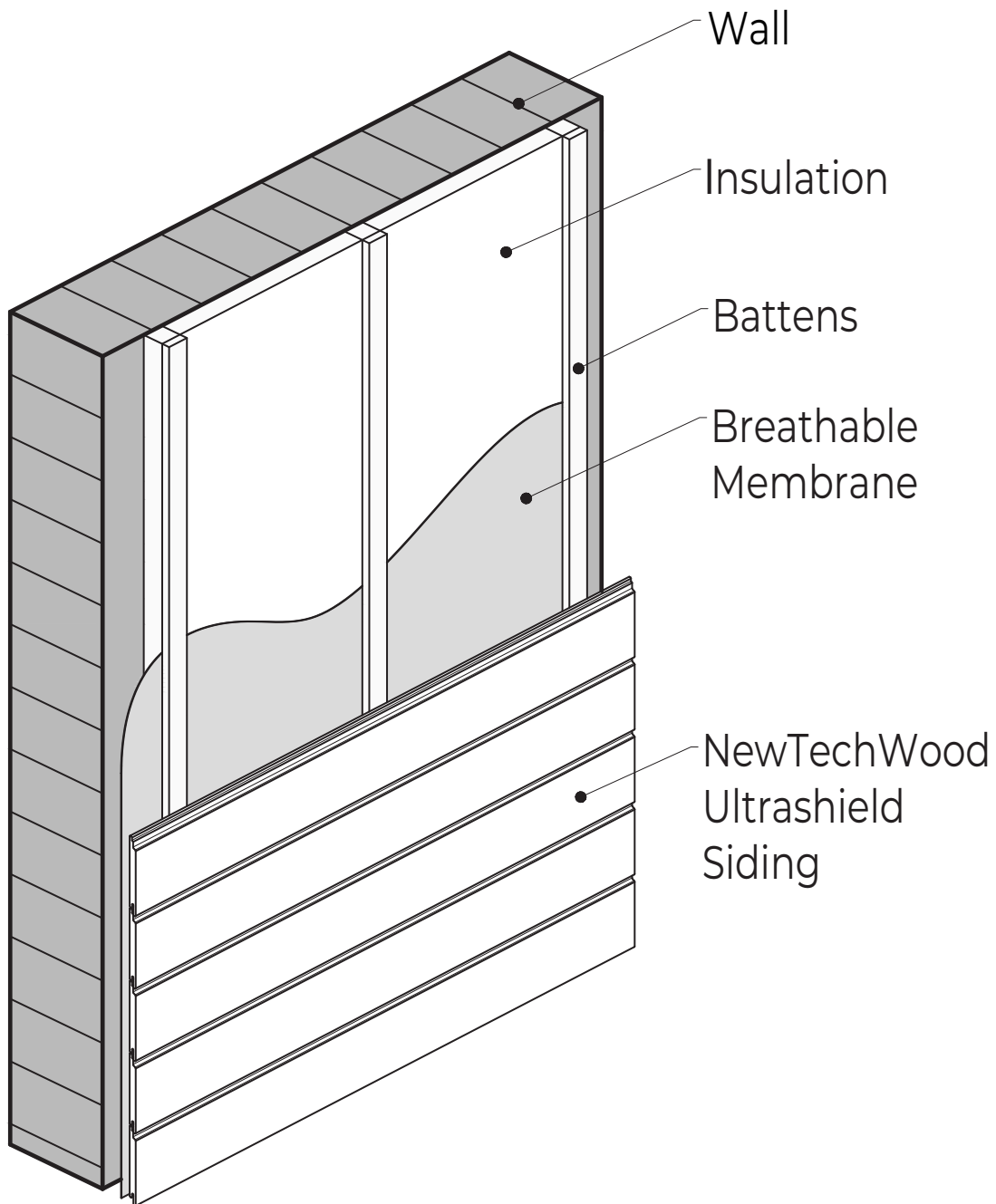
Product	Purpose	Part
*M3 x 12 SS304 (Part code: WJ063)	Used when locking the board into AW08 (Screws supplied by NTW)	
*8G x 20 SS410 (Pan Head)	Used when installing AW08 into aluminum batten (Screws not included, sourced / supplied by builder/installer)	
*8G x 20 SS410 (Flat Head)	Use when installing trims into aluminum batten (Screws not included, sourced / supplied by builder/installer)	

**\*Note:** All screws are based on our recommendation and if the installation requires something different than what is shown, a professional should be consulted before installing.

The following installation guide will use the above screw sizes.

## Under Construction

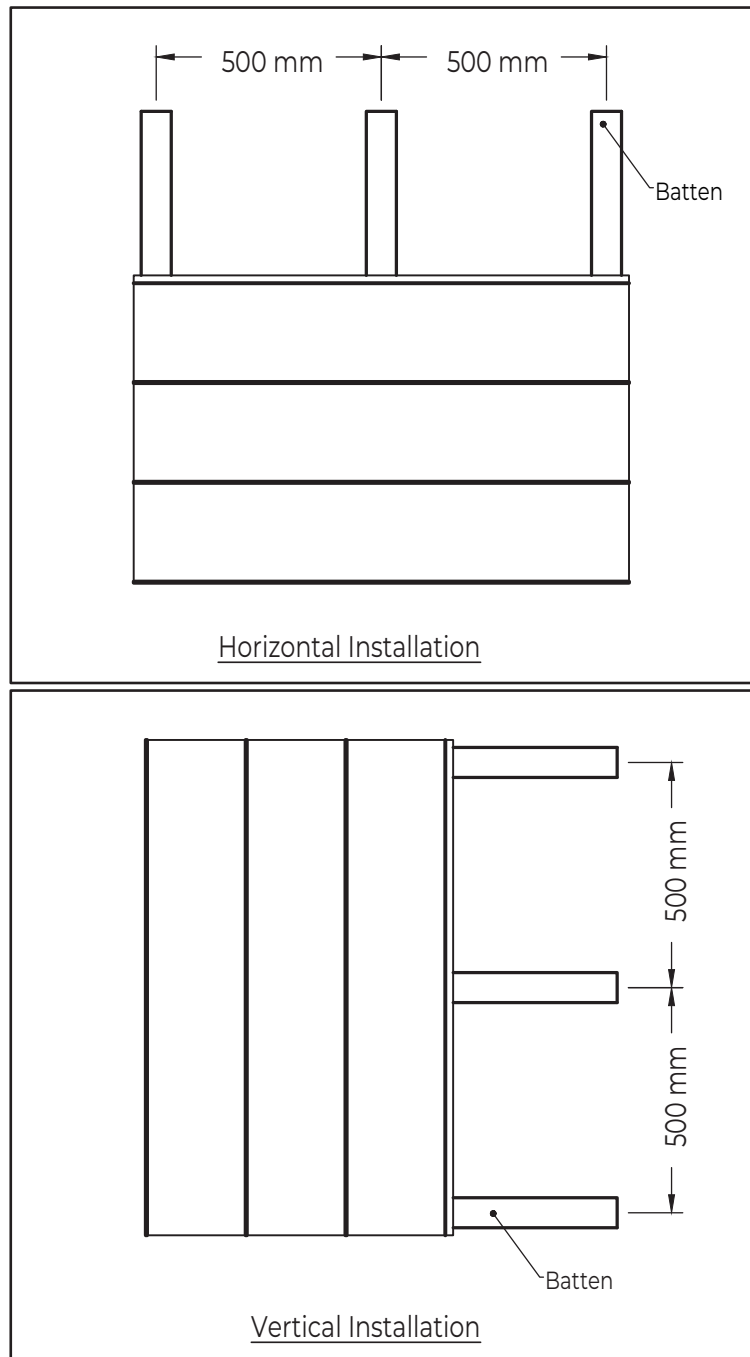
We recommend for the under construction Metal / Aluminum Top Hat Battens or Pre-primed H3 Timber Battens. Each cladding board needs to be supported by a batten NO MORE than 500 mm on centers. Extra care is required in order to provide sufficient joisting in and around obstacles such as windows, fascia's, soffits, guttering, ventilation points etc. Below is an example of the layers that would occur in a typical installation, but a licensed professional should always be consulted prior to any installation.



## Battens Installation

A building professional should be consulted regarding vapor barriers and insulation for your project. Where a vapor barrier is to be used, it should be a breathable type and must be positioned behind the battens. The batten needs to have a minimum thickness of 25 mm.

Battens should be fixed into position at a maximum of 500 mm on centers using a suitable A4 Stainless Steel Countersunk Wood/Masonry screw. All battens need to be flat and leveled against the wall surface use shims if necessary.



# Expansion and Contraction Values

NewTechWood cladding boards will experience expansion and contraction with changes in temperature. Expansion and contraction are most significant where extreme temperature changes occur. Fastening the cladding boards according to the gapping requirements noted in the following table accommodates for this movement.

		Length (Meters)								
		1	2.44	2.8	3	3.66	4	4.88	5.4	
Installation Temperature (° C)	0	1.4	3.4	3.9	4.2	5.1	5.6	6.8	7.6	Gap (mm)
	5	1.2	2.9	3.4	3.6	4.4	4.8	5.9	6.5	
	10	1.0	2.4	2.8	3.0	3.7	4.0	4.9	5.4	
	15	0.8	2.0	2.2	2.4	2.9	3.2	3.9	4.3	
	20	0.6	1.5	1.7	1.8	2.2	2.4	2.9	3.2	
	25	0.4	1.0	1.1	1.2	1.5	1.6	2.0	2.2	
	30	0.2	0.5	0.6	0.6	0.7	0.8	1.0	1.1	

**Please Note:**

1. The above table shows the overall gap required. If boards have a gap at each end, then halve the value shown.
2. If you are still unsure of what gapping to use, contact the manufacturer and they will give you the correct gapping requirements based on your environment and area.

# Locking the Wall Cladding Board

Every AW-08 clip comes with a separate hole in the case there is a need to lock the board. The wall cladding boards will expand and contract and to take care of this movement, we must lock the board in one position, **ONLY ONE LOCKING SCREW USED PER BOARD**, and then allow the board to expand and contract readily in the other direction.

Please Note: **DO NOT LOCK EVERY CLIP**. General rule of thumb is every board will only need one locking/fixation point.

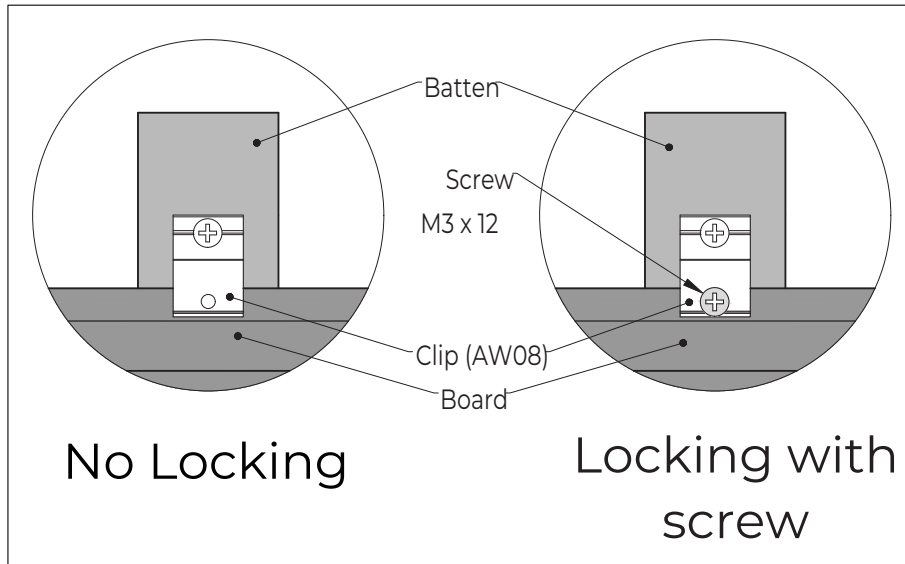


Diagram A

## Horizontal Installation

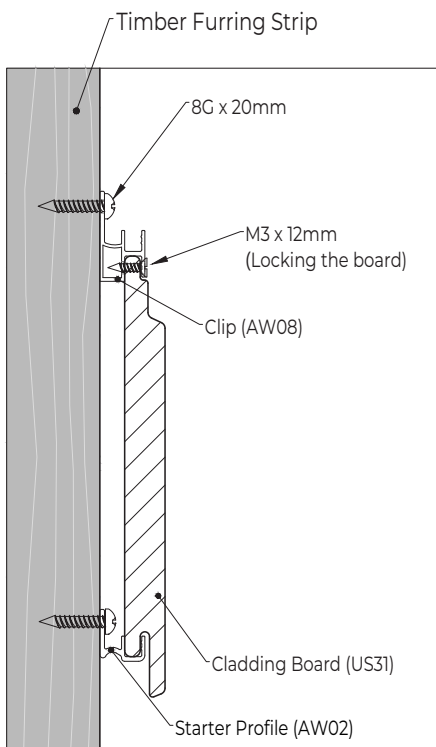


Diagram B

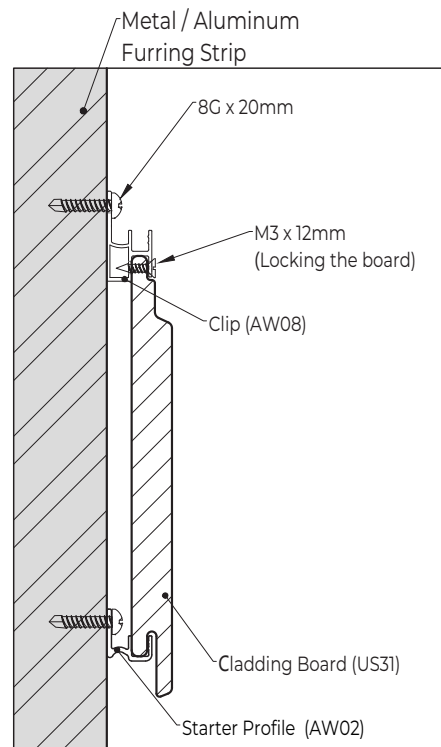
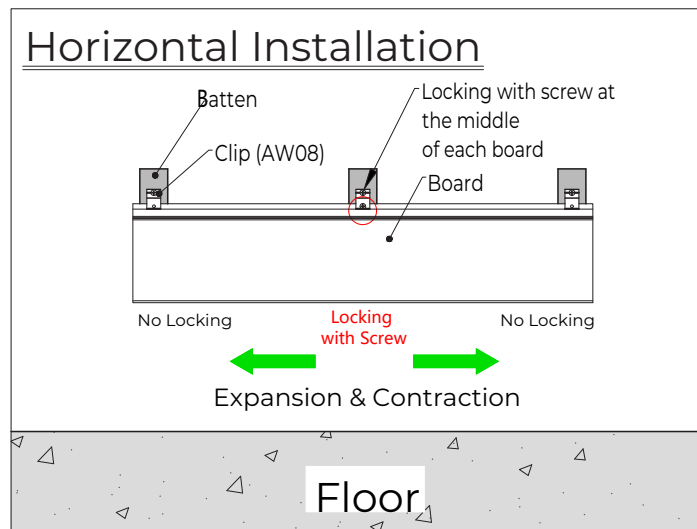


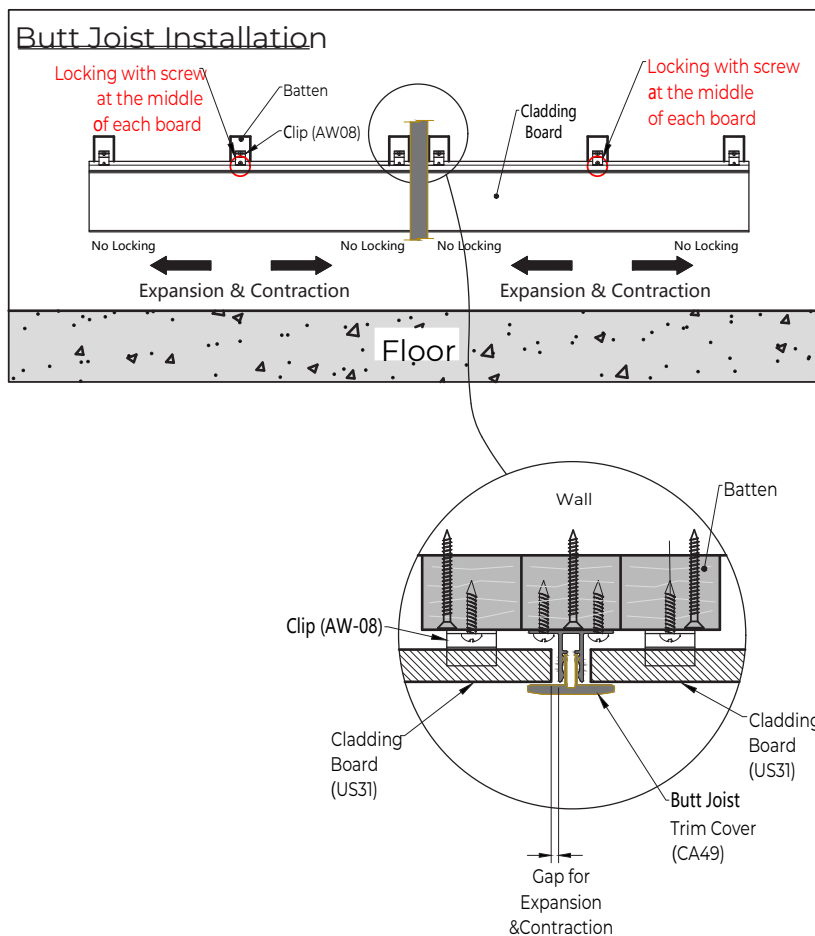
Diagram C

When installing horizontally, it is required to lock the Clip (AW08) at the middle of the board, as shown in **Diagram D**.



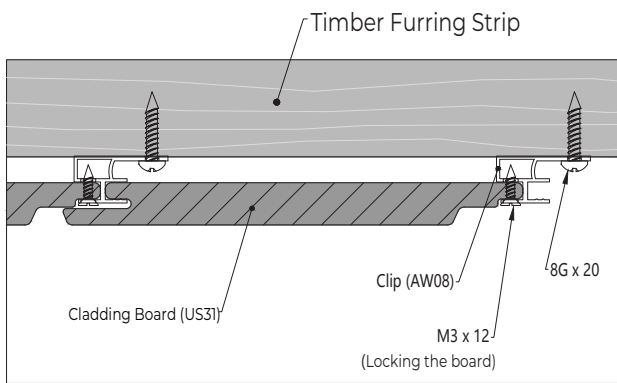
**Diagram D**

When installing more than one board horizontally, it is recommended to utilize the Butt Joist Trim (Base AA45 and Cover CA49) at each butt joint. It is also required to lock the Clip (AW08) at the middle of each board, as shown in **Diagram E**.

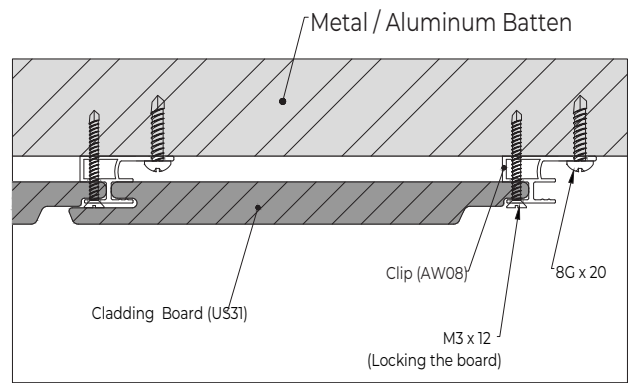


**Diagram E**

## Vertical Installation

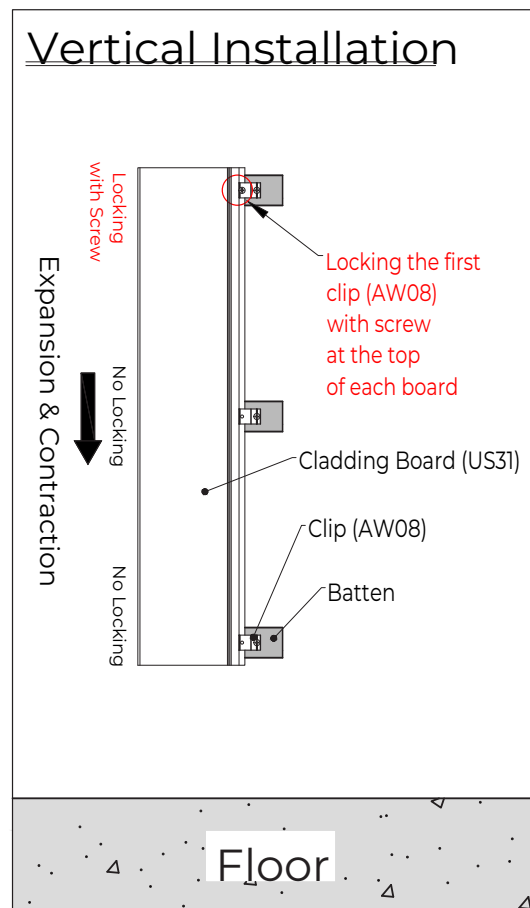


**Diagram F**



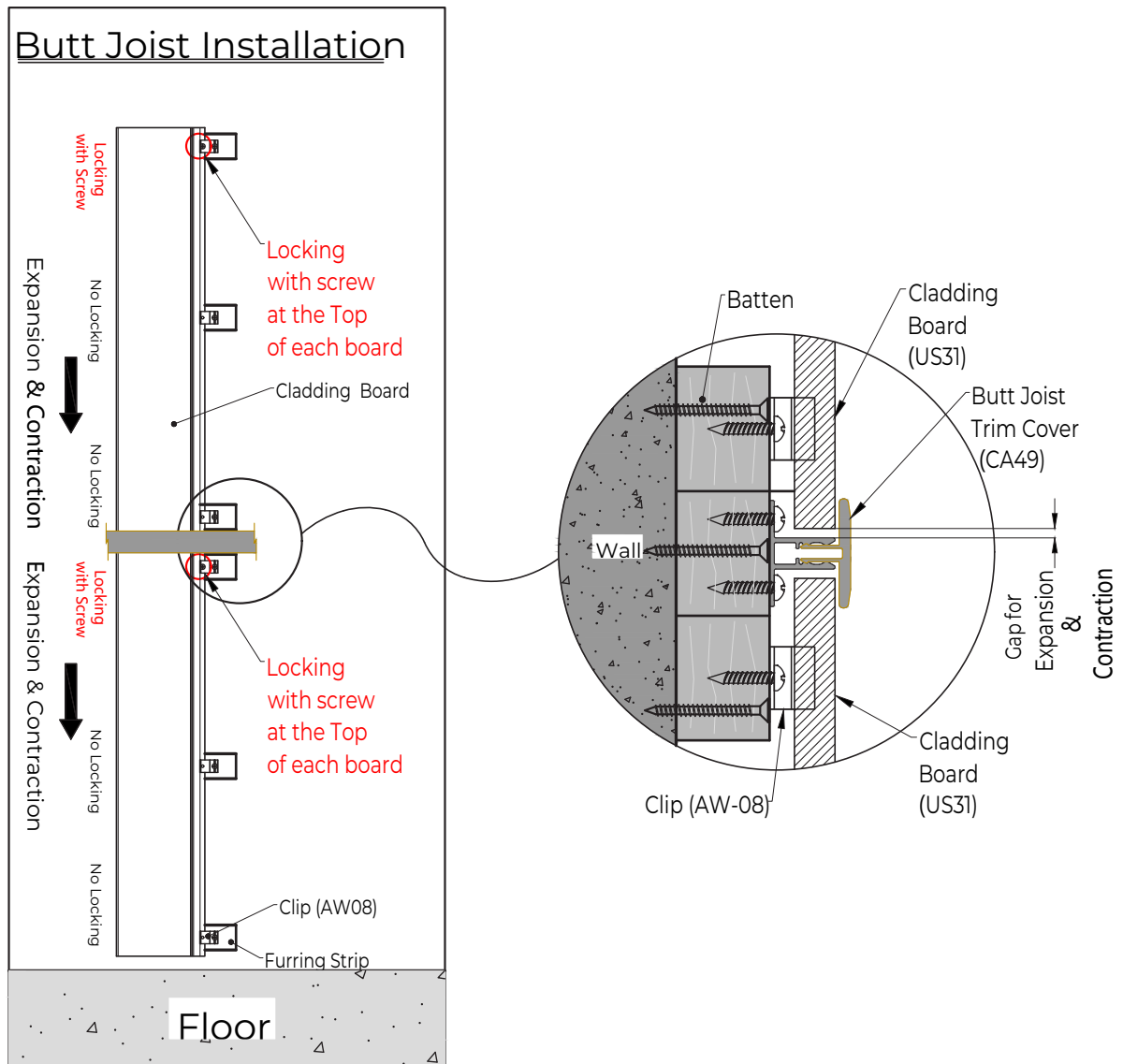
**Diagram G**

When installing vertically, it is required to lock the Clip (AW08) at the top of the board, as shown in **Diagram H**.



**Diagram H**

When installing more than one board horizontally, it is recommended to utilize the Butt Joist Trim (Base AA45 and Cover CA49) at each butt joint. It is also required to lock the Clip (AW08) at the top of each board, as shown in **Diagram I**.



**Diagram I**



# Wall Cladding-Horizontal Installation

## Installation Procedure

Step 1: Framing - Measure and Chalk the battens

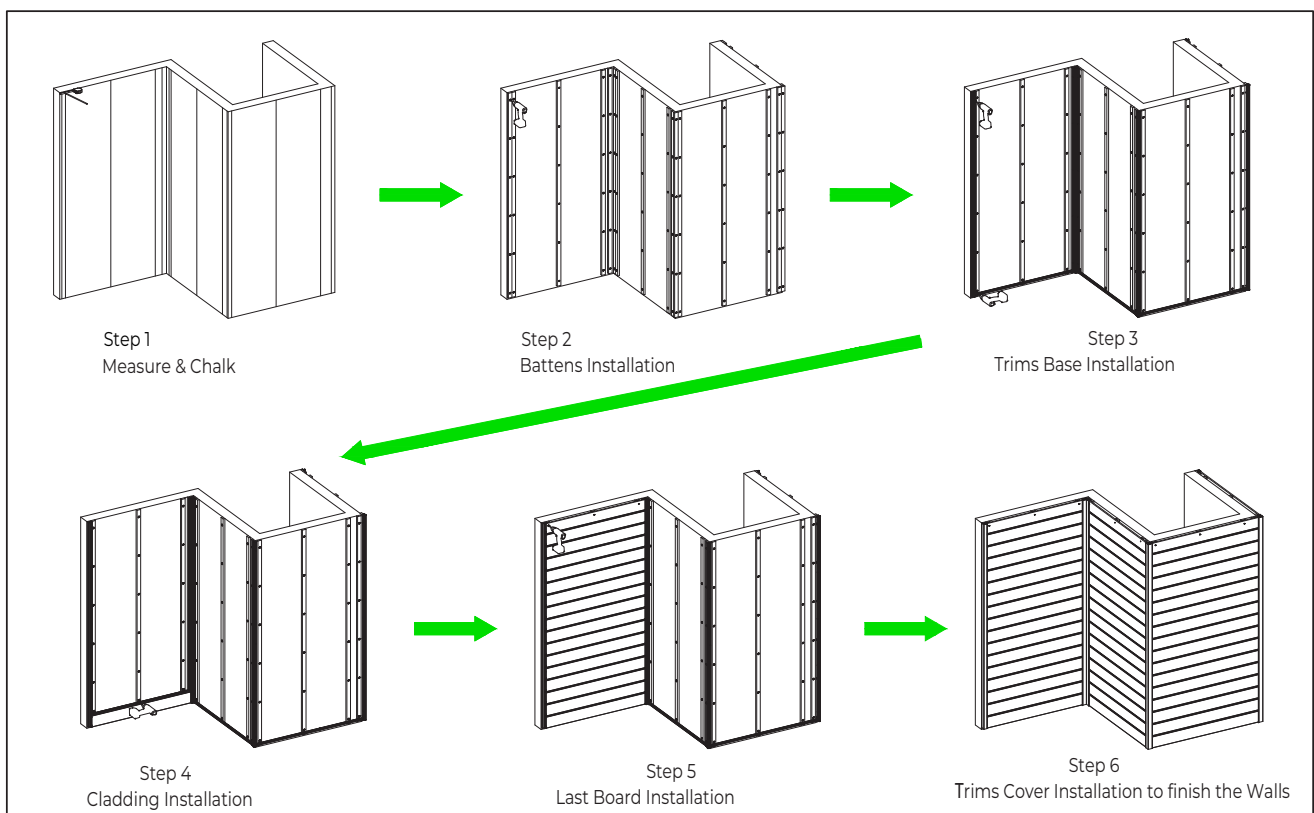
Step 2: Framing - Battens Installation

Step 3: Install the Aluminum Trim Base

Step 4: Install the Cladding Boards

Step 5: Install the last Boards

Step 6: Install the Capped Aluminum Cover to finish the walls.



## 1.1 Framing

The frame needs to be level before installing the cladding boards. **Diagram 1.1** shows the wall replicating different scenarios potentially occurring when installing the cladding boards.

### Wall Side A:

Cladding between the Outermost Edge to the Inside Corner.  
Use the End Trim (Base AA44 and Cover CA48) and the Inside Corner Trim (Base AA46 and Cover CA50).

### Wall Side B:

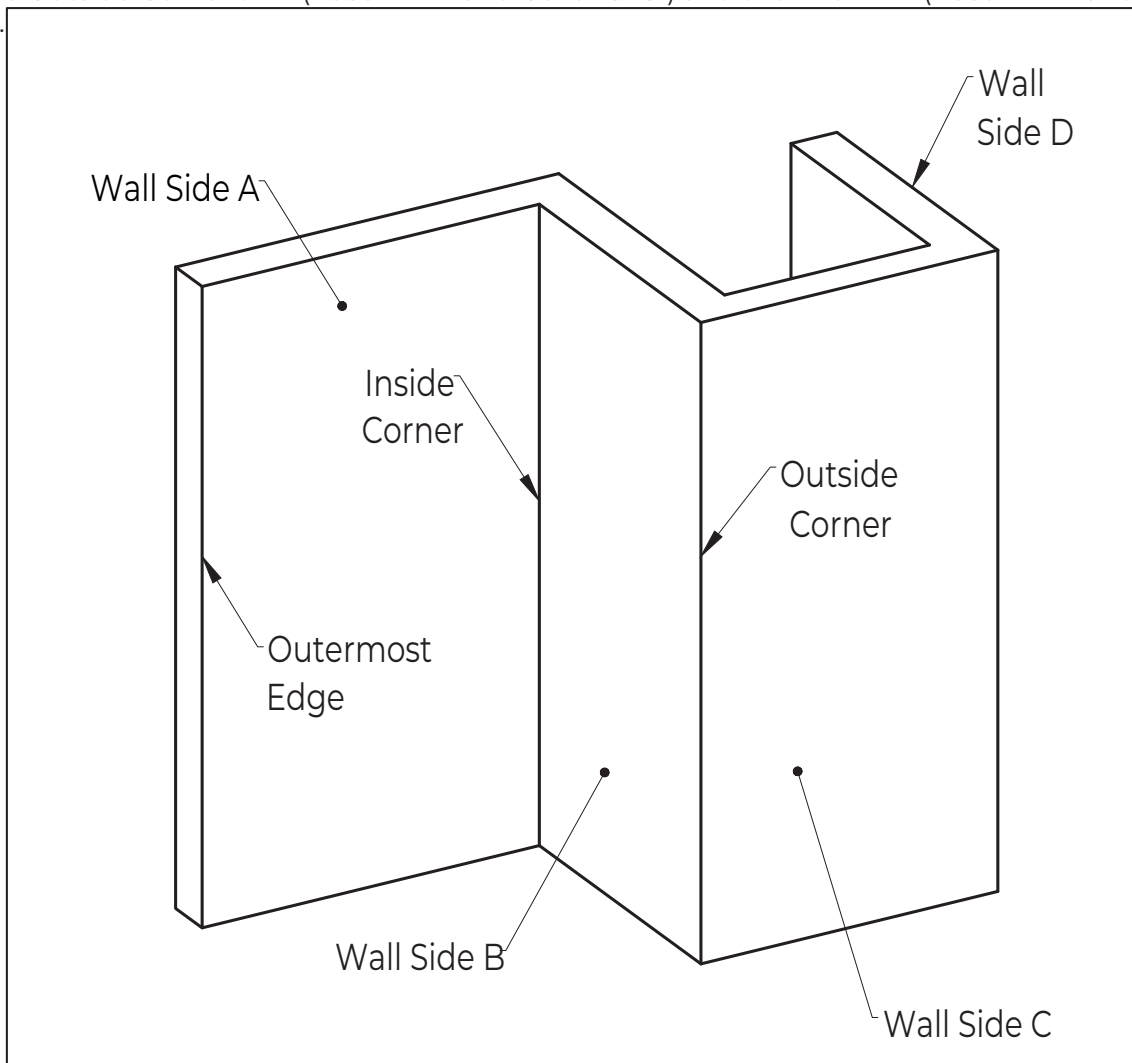
Cladding between the Inside Corner to the Outside Corner.  
Use the Inside Corner Trim (Base AA46 and Cover CA50) and the Outside Corner Trim (Base AA47 and Cover CA51).

### Wall Side C:

Cladding between two Outside Corner.  
Use the Outside Corner Trim (Base AA47 and Cover CA51)

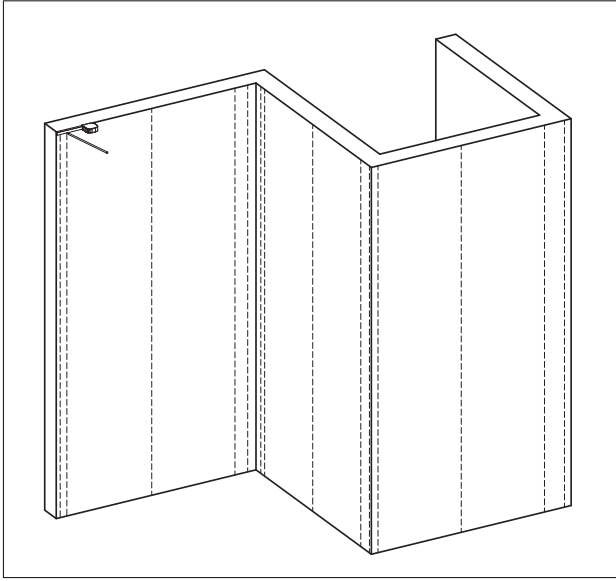
### Wall Side D:

Cladding between the Outside Corner and the Outermost Edge,  
Use the Outside Corner trim (Base AA47 and Cover CA51) and the End Trim (Base AA44 and Cover CA48).



**Diagram 1.1**

- 1.2** Measure and chalk the battens according to the span data specified on [Page 11](#) of this installation guide, as shown in [Diagram 1.2](#).



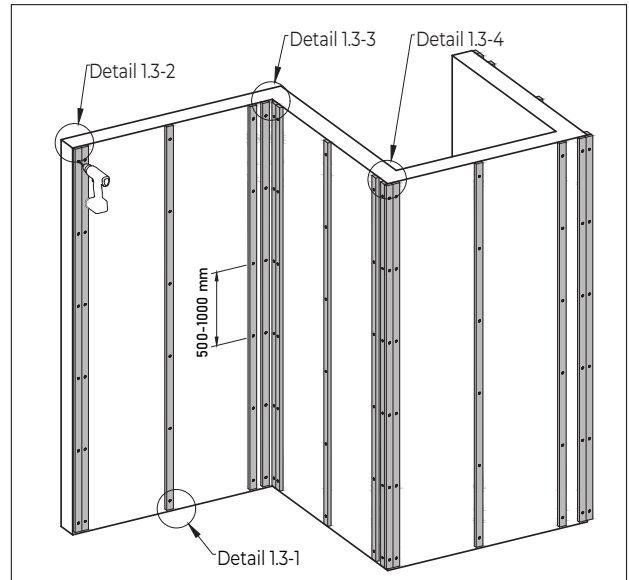
**Diagram 1.2**

**Please Note:**

1. We are using timber battens for this installation. If you are using metal/ aluminium batten, please refer to [page 9](#) of this installation guide for the correct recommended screws.

2. An adequate span between the battens is required to keep the Cladding Boards from bending. Please review [page 11](#) of this installation guide to see what span is needed.

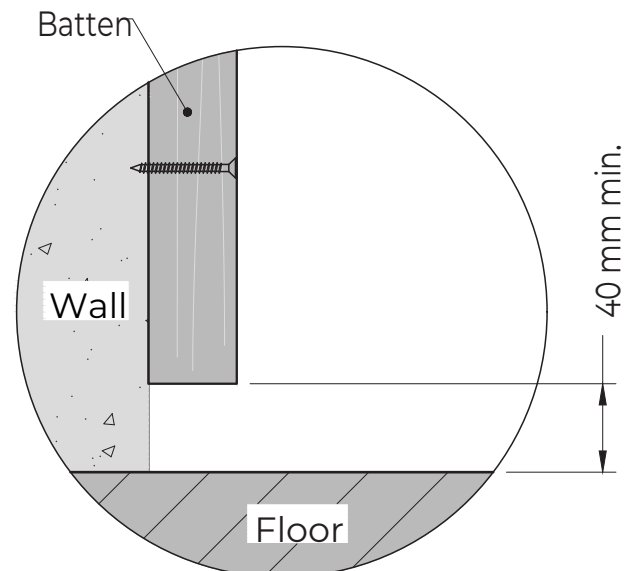
- 1.3** Fix the battens onto the wall that you intend to install with screws in the distance at least 500mm and max to 1000mm on center, as shown in [Diagram 1.3](#).



**Diagram 1.3**

**Please Note:**

1. A minimum gap of 40mm needs to be left between the batten and the floor, as shown in [Detail 1.3-1](#).

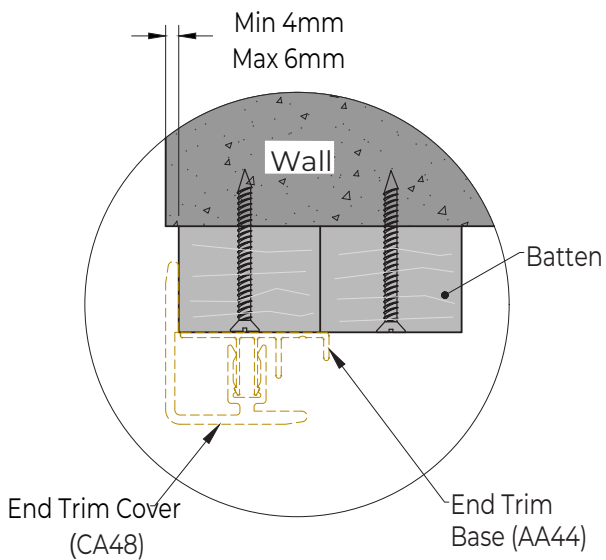


**Detail 1.3-1**

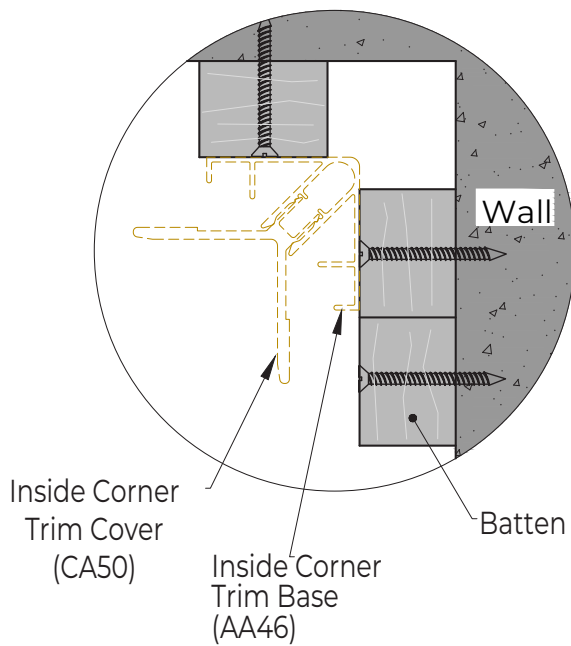
## 1.3 Continued

**Please Note:**

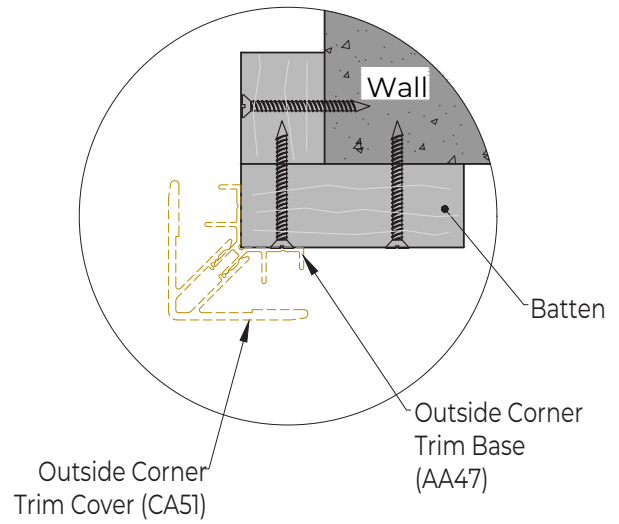
1. For the Outermost Edge, please install according to **Detail 1.3-2**.
2. For the Inside Corner, please install according to **Detail 1.3-3**.
3. For the Outside Corner, please install according to **Detail 1.3-4**.



**Detail 1.3-2**



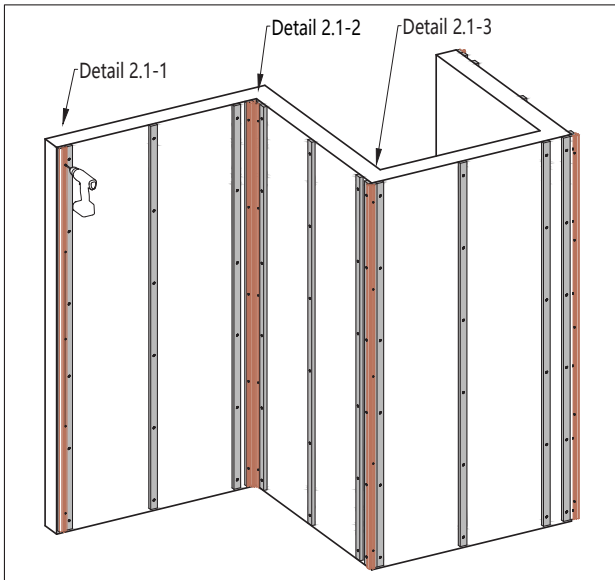
**Detail 1.3-3**



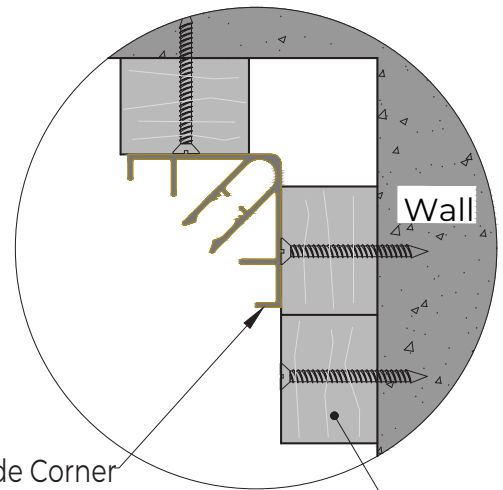
**Detail 1.3-4**

## 2.1 Install the Trim Bases

Fix the trim bases onto the Inside Corners, Outside Corners and the Outermost Edges with screws in the distance at least 500 mm and max 1000 mm, as shown in **Diagram 2.1**, **Detail 2.1-1**, **Detail 2.1-2**, and **Detail 2.1-3**.

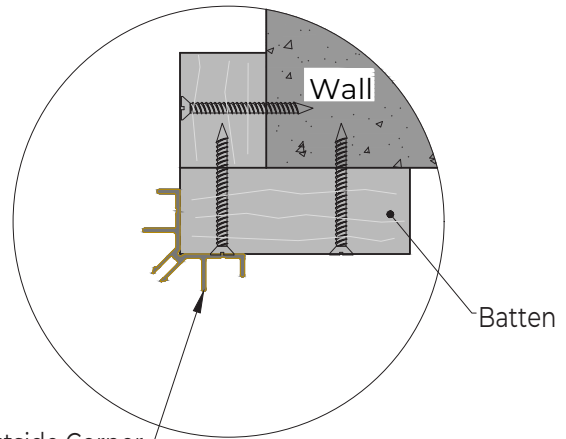


**Diagram 2.1**



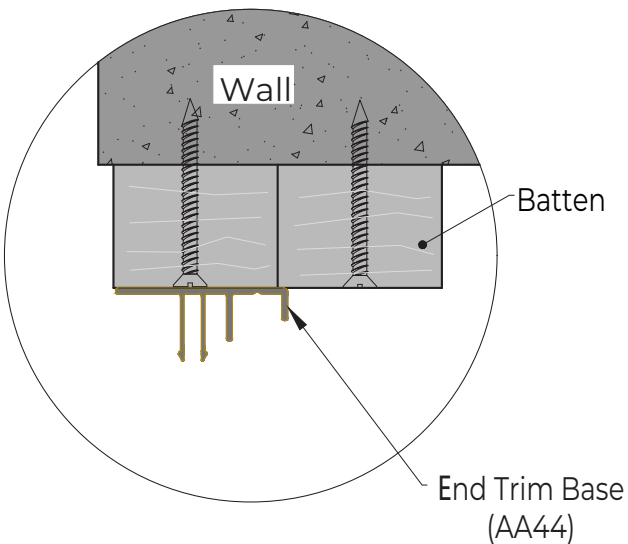
Inside Corner  
Trim Base  
(AA46)

**Detail 2.1-2**



Outside Corner  
Trim Base  
(AA47)

**Detail 2.1-3**

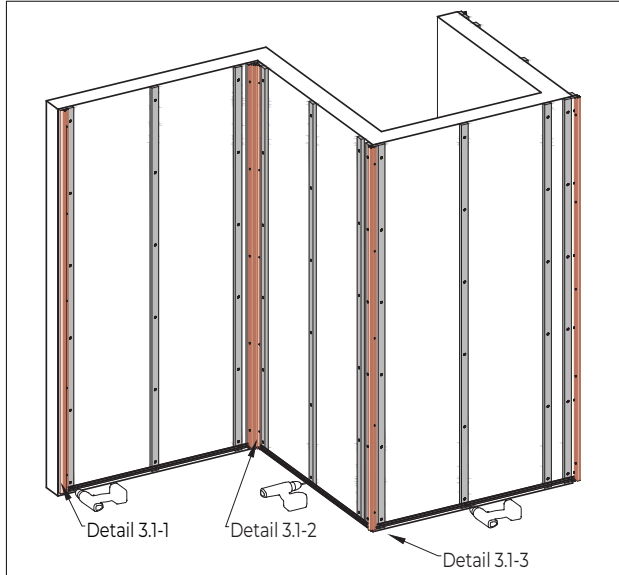


End Trim Base  
(AA44)

**Detail 2.1-1**

# Install the First Board

**3.1** Install the Starting Trim (AW02) at the bottom end of the battens against the floor with screws, as shown in **Diagram 3.1**.



**Diagram 3.1**

**Please Note:**

**1. Outermost Edge**

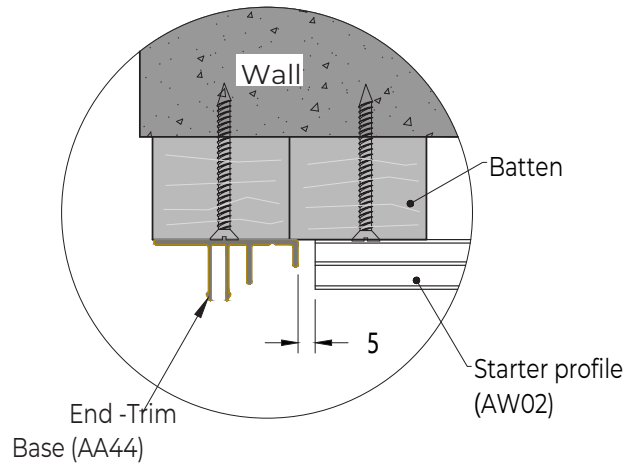
A min gap of 5 mm needs to be left between the Starter profile (AW02) and the End Trim base AA44), as shown in **Detail 3.1-1**.

**2. Inside Corner**

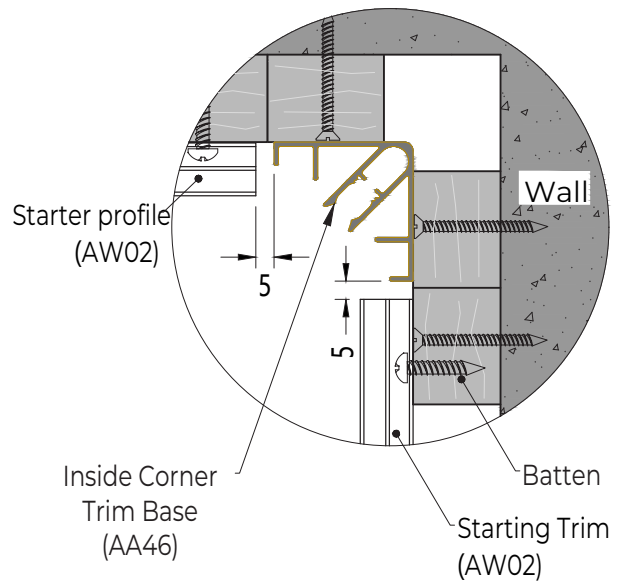
A min gap of 5 mm needs to be left between the Starting Trim (AW02) and the Inside Corner Trim Base (AA46), as shown in **Detail 3.1-2**.

**3. Outside Corner**

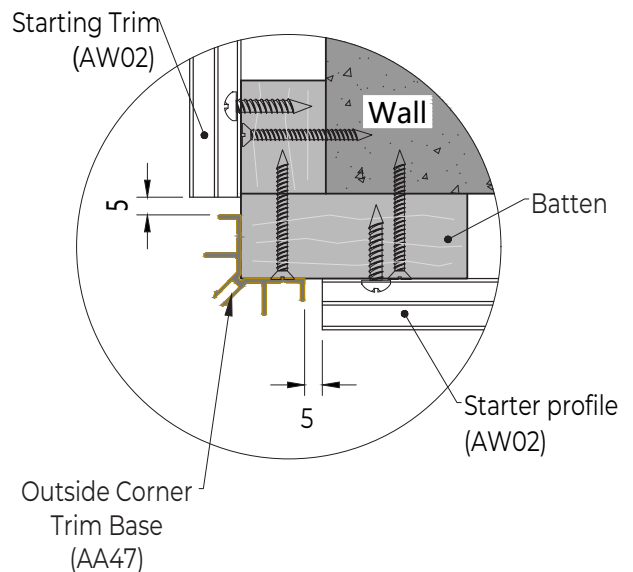
A min gap of 5 mm needs to be left between the Starter profile (AW02) and the Outside Corner Trim Base (AA47), as shown in **Detail 3.1-3**.



**Detail 3.1-1**

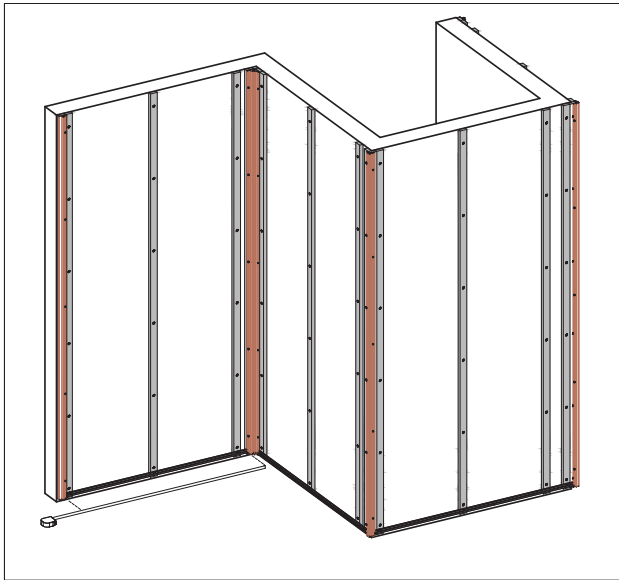


**Detail 3.1-2**



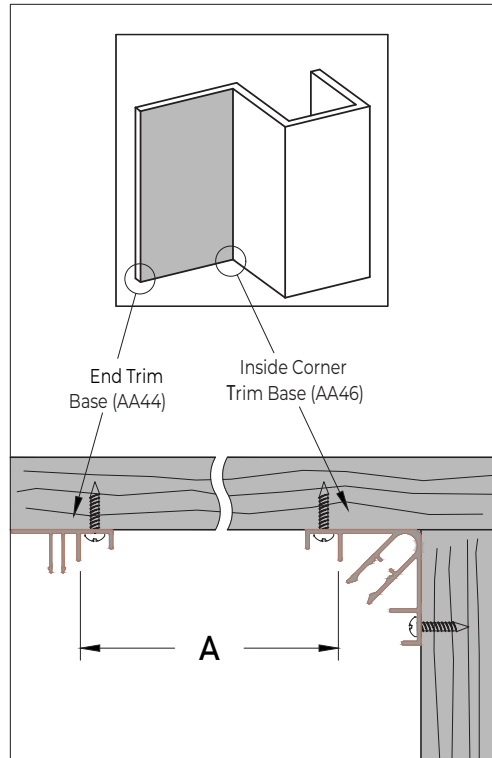
**Detail 3.1-3**

**3.2** Measure the distance between the trims and rip the cladding boards according to the measurement, as shown in **Diagram 3.2**, **Detail 3.2-1**, **Detail 3.2-2**, **Detail 3.2-3**, and **Detail 3.2-4**.



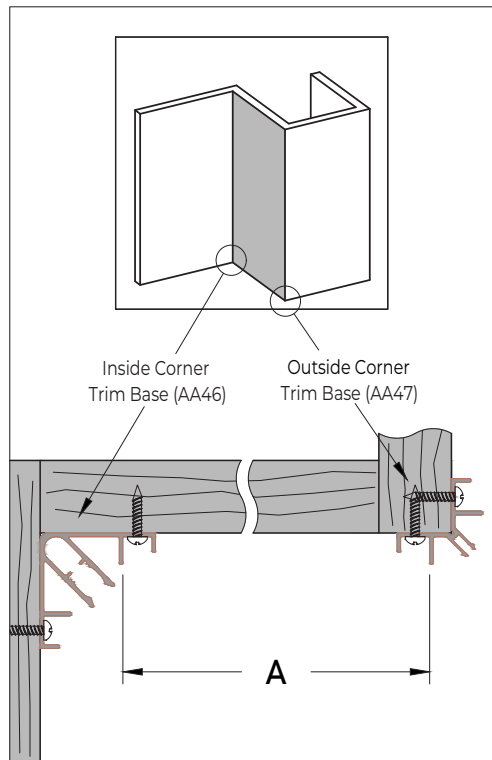
**Diagram 3.2**

Between the Outermost Edge and the Inside Corner



**Detail 3.2-1**

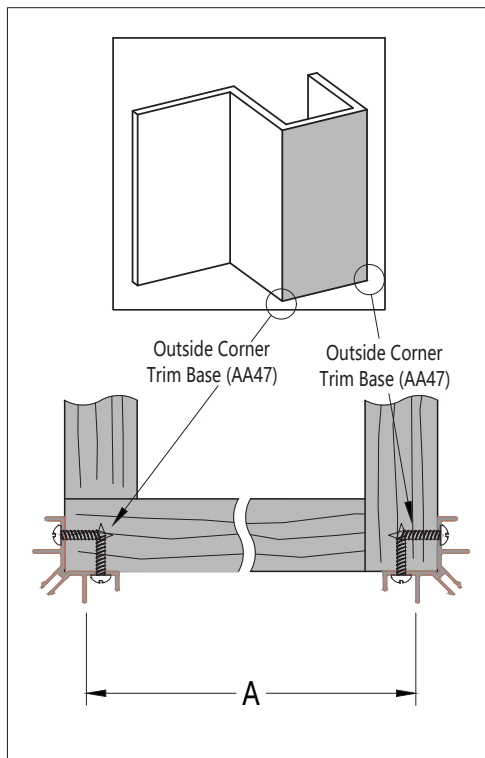
Between the Inside Corner and the Outside Corner



**Detail 3.2-2**

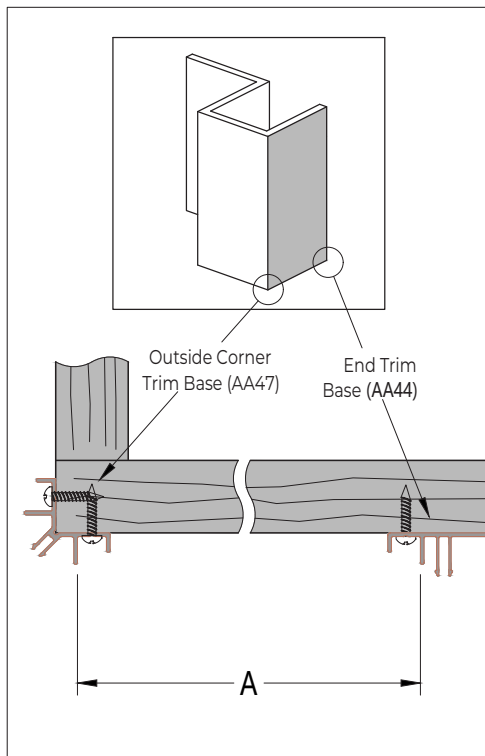
## 3.2 Continued

### Between two Outside Corners



**Detail 3.2-3**

### Between the Outside Corner and the Outermost Edge

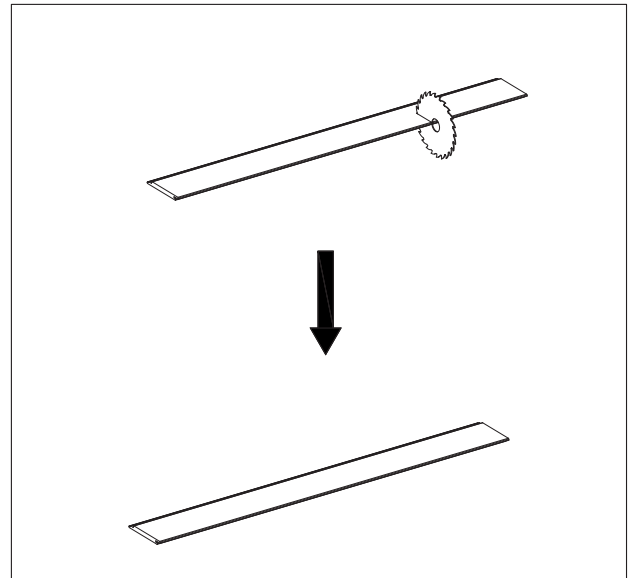


**Detail 3.2-4**

3.3

Calculate and Rip the boards according to the measurement, as shown in **Diagram 3.3**

Width of the boards = Measurement A - 6mm

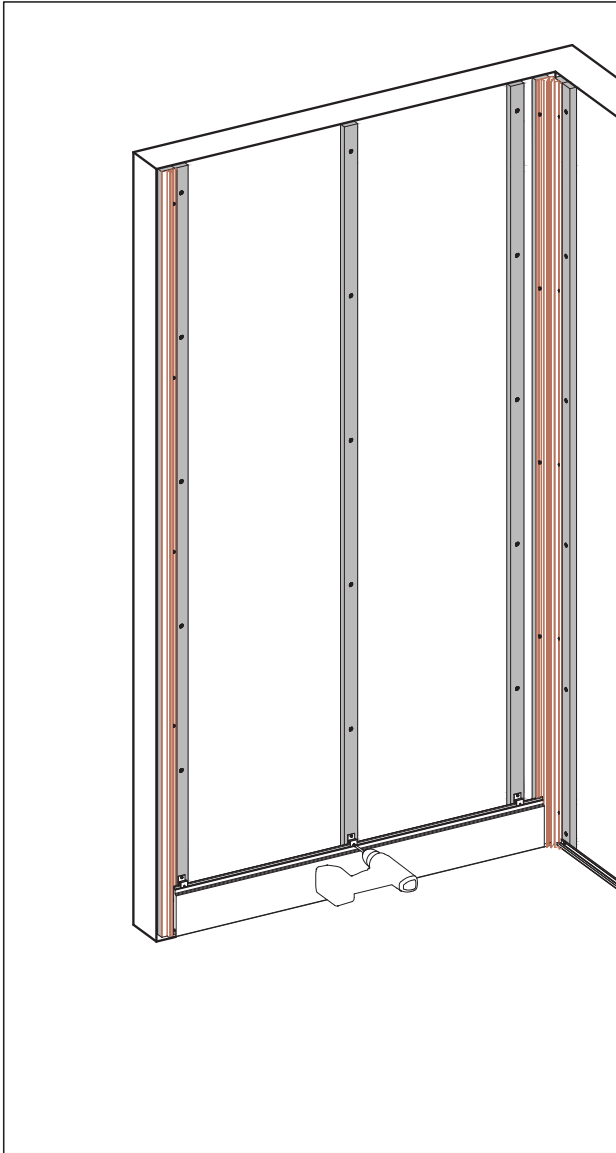


**Diagram 3.3**

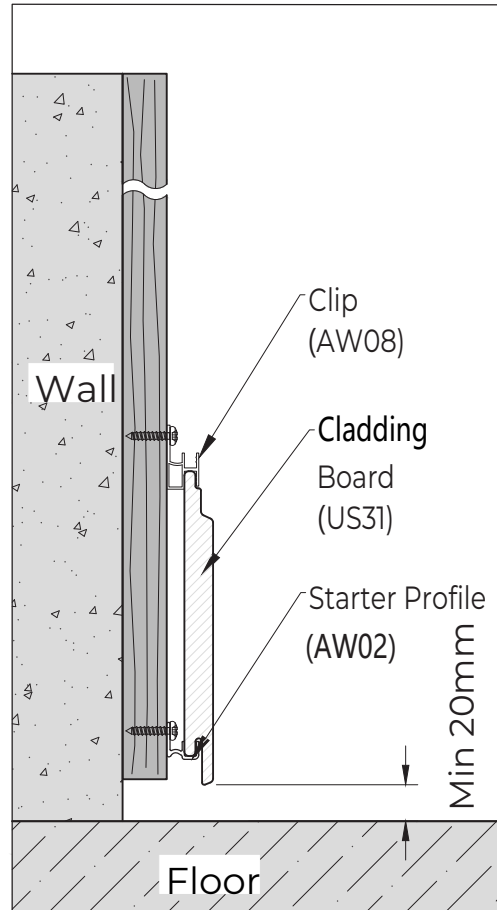


3.4

Put the first Cladding Board (US31) over the Starting Trim (AW02) and fasten it onto the batten with Clip (AW08). The clearance between the cladding board and the floor should be at least 20 mm, as shown in [Diagram 3.4](#) and [Detail 3.4-1](#)



[Diagram 3.4](#)

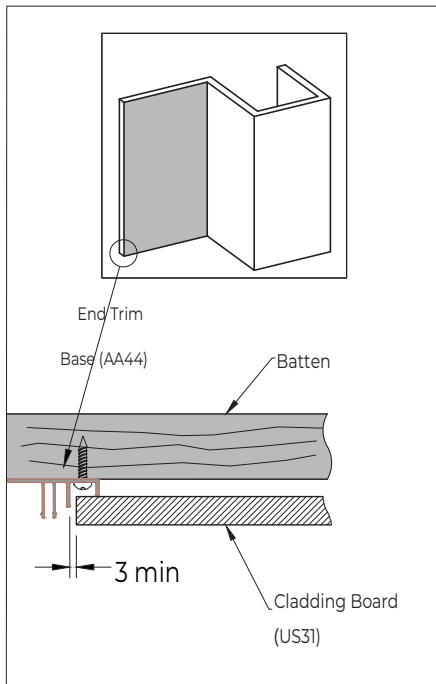


[Detail 3.4-1](#)

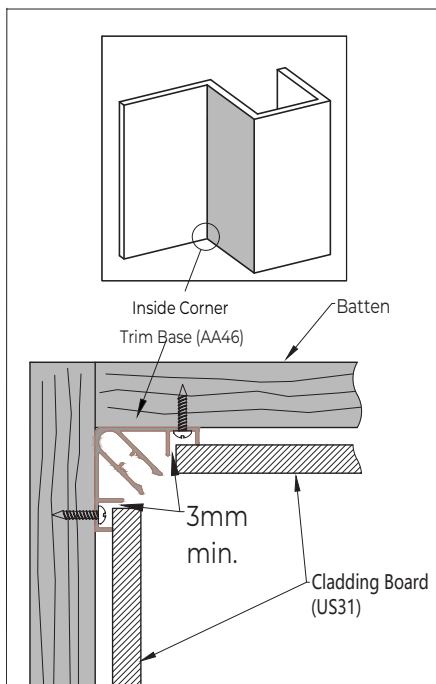
**Please Note:**

The gap between the Cladding Board, (US31), End Trim Base (AA44), Outside Corner Trim Base (AA47) and the Inside Corner Trim Base ( AA46) is vital to avoid warping or buckling, as shown in [Detail 3.4-2](#), [Detail 3.4-3](#), and [Detail 3.4-4](#).

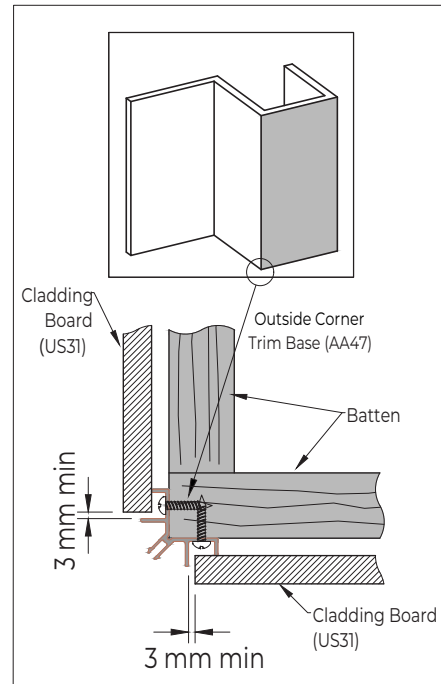
### 3.4 Continued



**Detail 3.4-2**



**Detail 3.4-3**



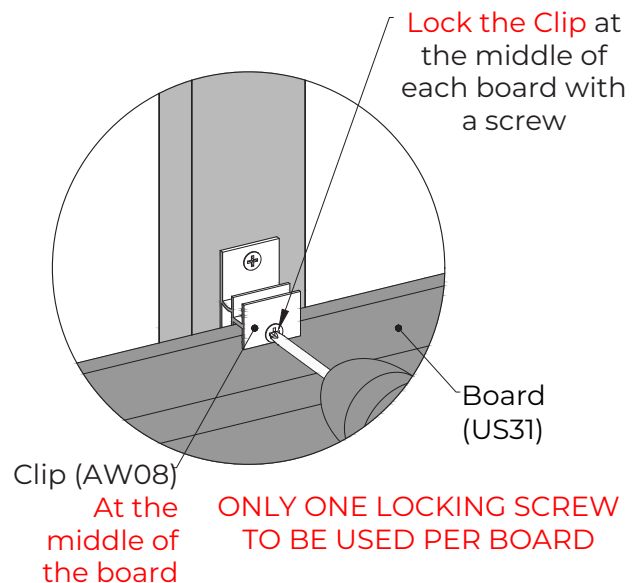
**Detail 3.4-4**

**Please Note:**

Since the composite wood must allow for expansion and contraction due to temperature change, the board must be **locked at one fixed point but only one point** to allow the remaining board to move freely. When installing horizontally, it is required to **lock the Clip (AW08) at the middle of each board**, as shown in **Detail 3.4-5**.

**DO NOT LOCK** any other Clip (AW08) for the same board.

Please review **page 12, "Locking the Wall Cladding Board"** of this installation guide for further information.



**Detail 3.4-5**

## Install the Second Board

- 4.1** Put the second Cladding Board (US31) over the first board's Clip (AW08) and fasten it with the Clip (AW08), as shown in Diagram 4.1 and Detail 4.1-1.

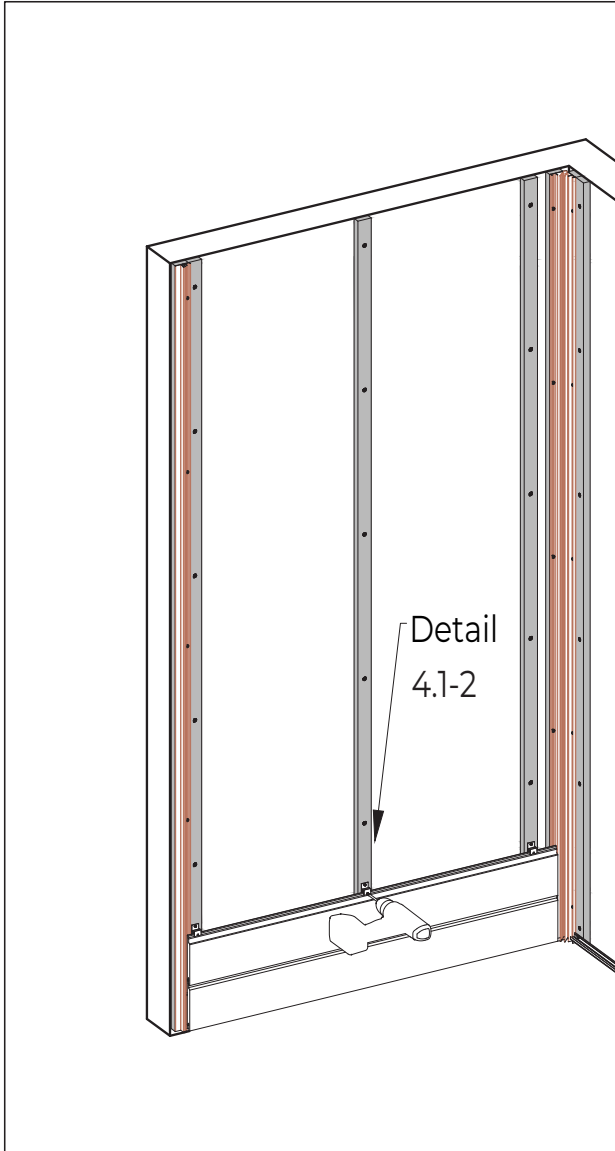
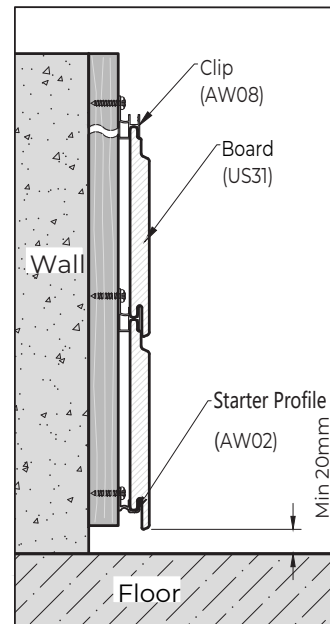
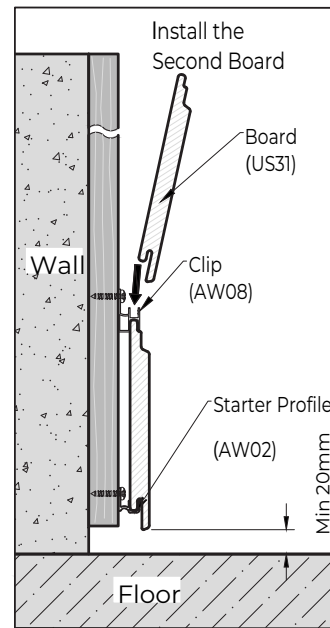


Diagram 4.1



Detail 4.1-1

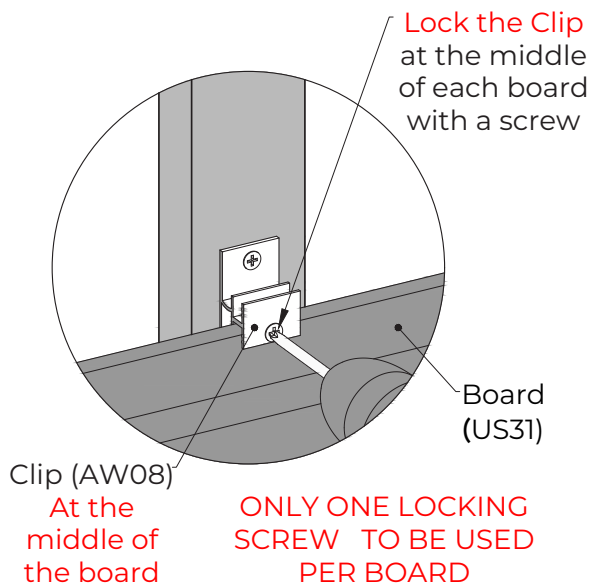
## 4.1 Continued

### Please Note:

Since the composite wood must allow for expansion and contraction due to temperature change, the board must be **locked at one fixed point but only one point** to allow the remaining board to move freely. When installing horizontally, it is required to **lock the Clip (AW08) at the middle of each board**, as shown in **Detail 4.1-2**.

**DO NOT LOCK** any other Clip (AW08) for the same board.

Please review **page 12, "Locking the Wall Cladding Board"** of this installation guide for further information.

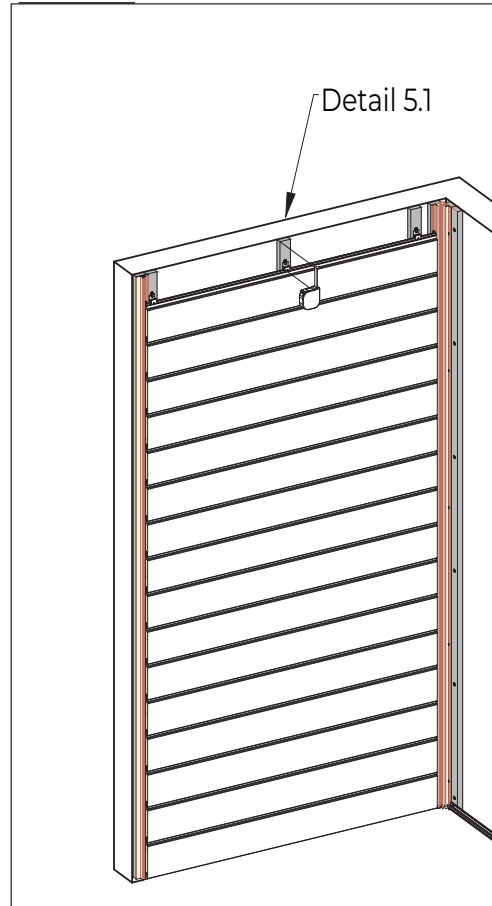


**Detail 4.1-2**

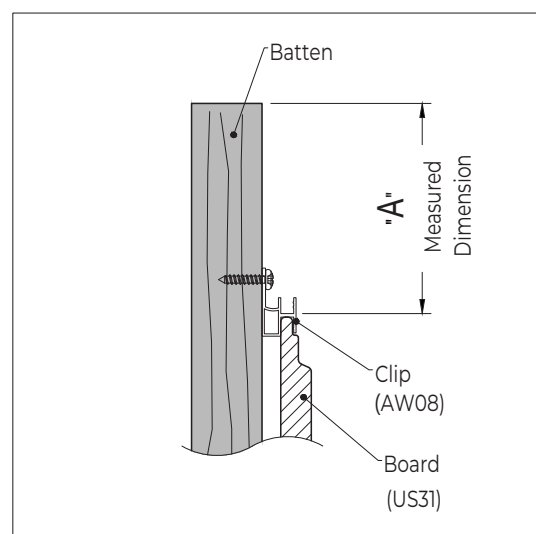
## Install the Last Board

**5.1**

When you are at the last board, measure the distance between the top end of the batten and the Clip (AW08), as shown in **Diagram 5.1** and **Detail 5.1**.

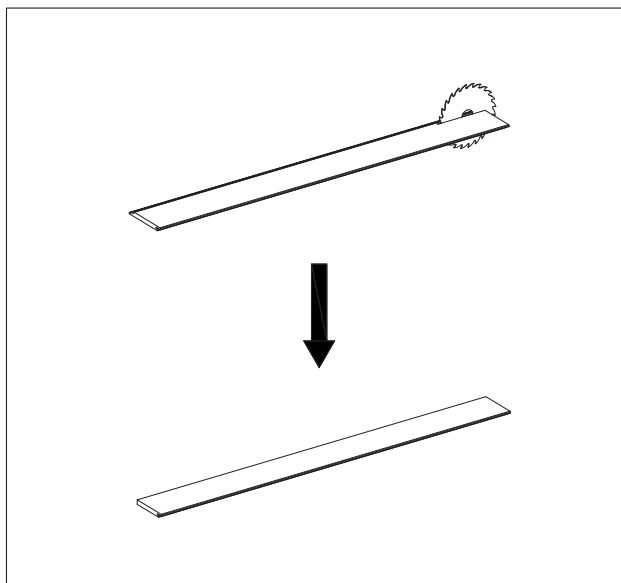


**Diagram 5.1**

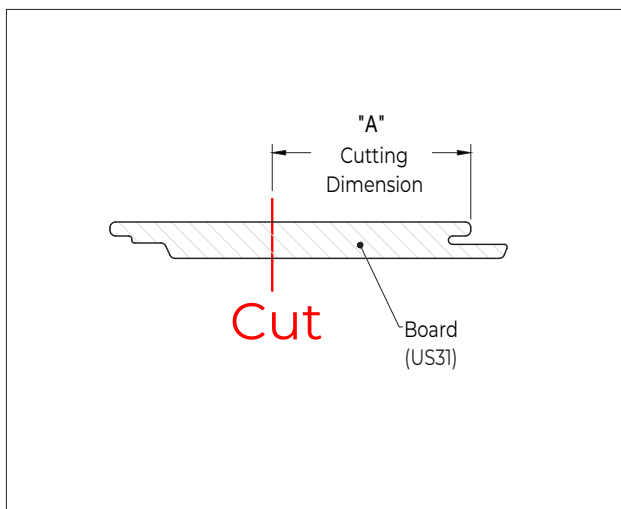


**Detail 5.1**

**5.2** Rip the board according to the measured dimension, as shown in **Diagram 5.2** and **Detail 5.2**.

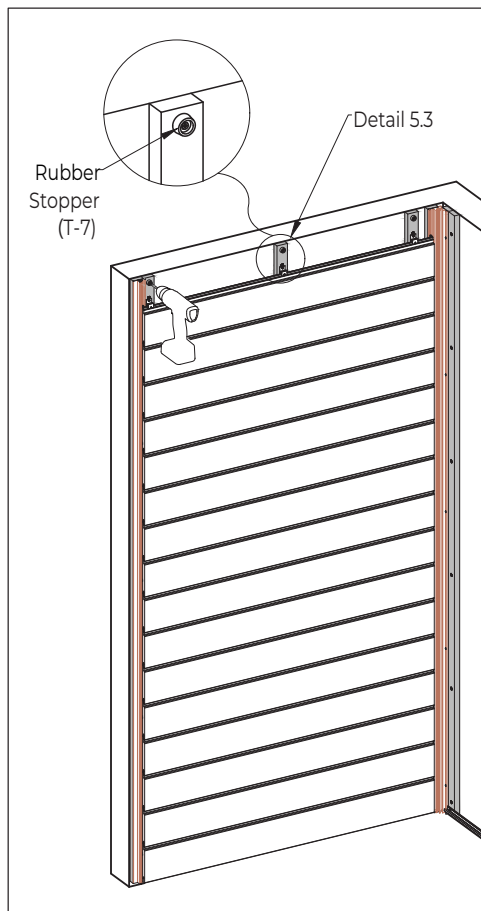


**Diagram 5.2**

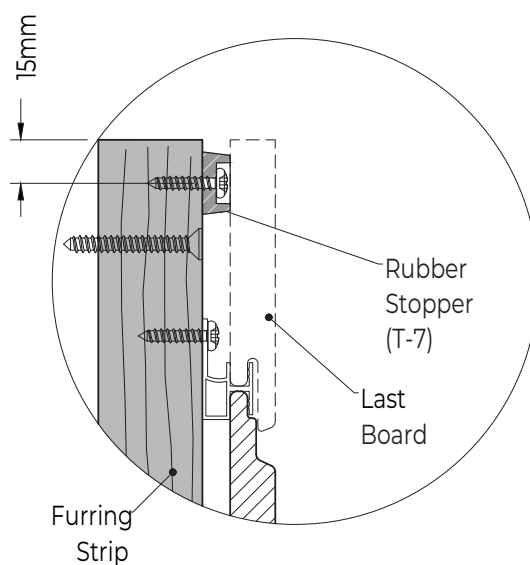


**Detail 5.2**

**5.3** Install the Rubber Stopper (T-7) onto each batten with screws, as shown in **Diagram 5.3** and **Detail 5.3**.

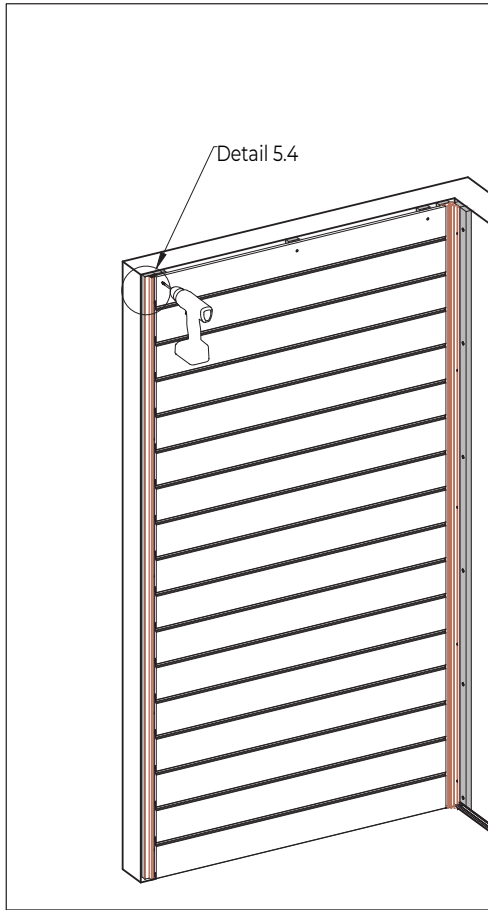


**Diagram 5.3**

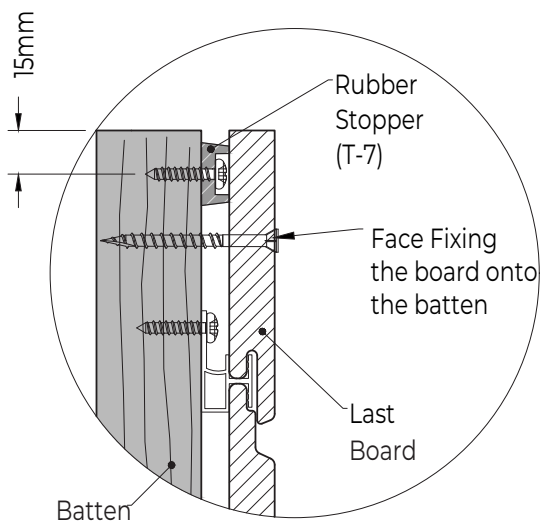


**Detail 5.3**

**5.4** Put the ripped cladding board over the Clip (AW08) in place and then face fix it onto each batten along the length of the board against the Rubber Stopper (T-7), as shown in Diagram 5.4 and Detail 5.4.



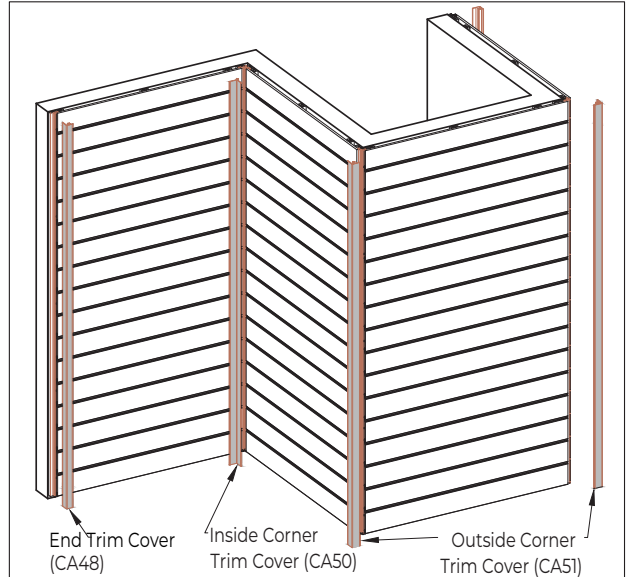
**Diagram 5.4**



**Detail 5.4**

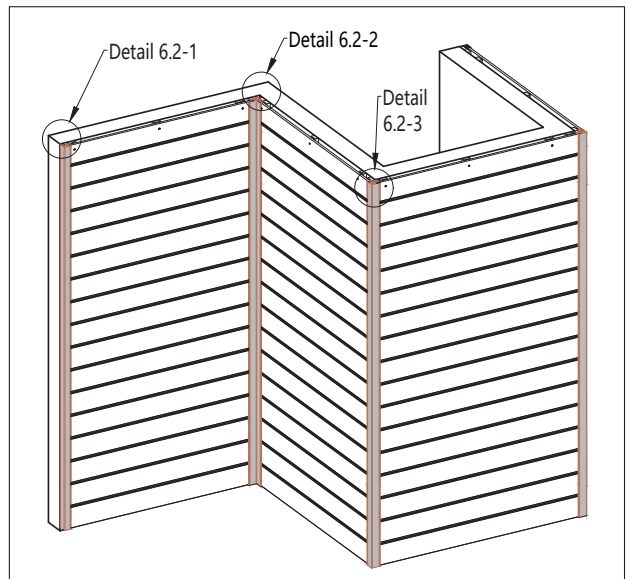
## Install the Trim Covers to finish the walls

**6.1** Put the trim cover against the trim base, as shown in Diagram 6.1



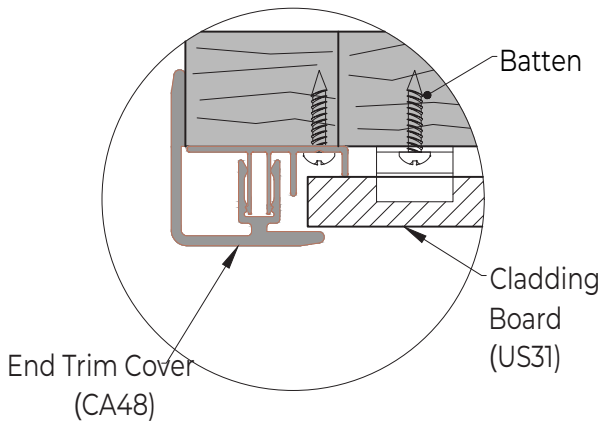
**Diagram 6.1**

**6.2** Use a rubber mallet to hammer the cover to snap with the base securely, as shown in Diagram 6.2, Detail 6.2-1, Detail 6.2-2, and Detail 6.2-3

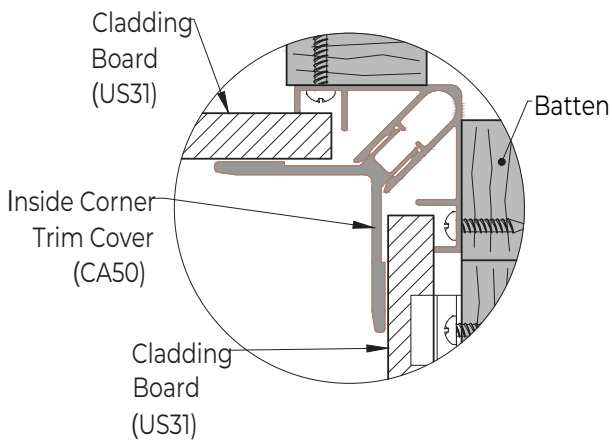


**Diagram 6.2**

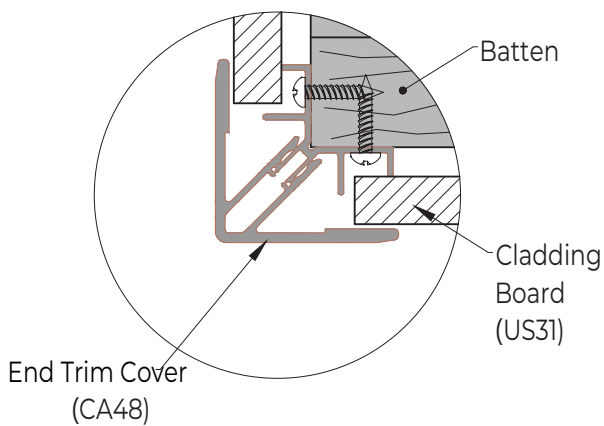
## 6.2 Continued



**Detail 6.2-1**



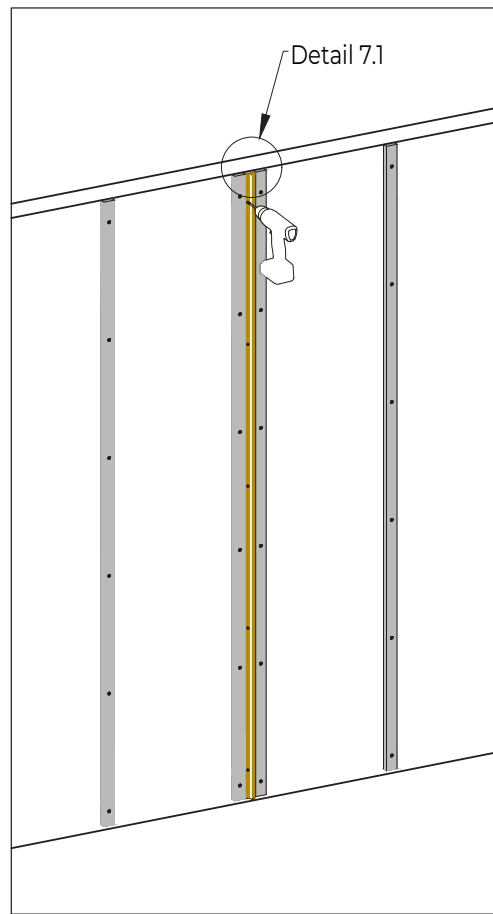
**Detail 6.2-2**



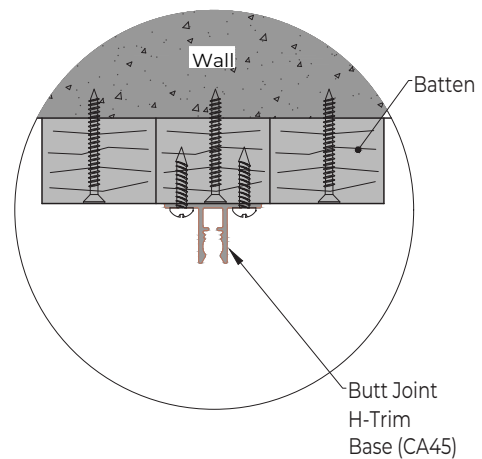
**Detail 6.2-3**

## Butt Joist Installation

**7.1.** Fix the battens onto the wall with screws, as shown in **Diagram 7.1**.



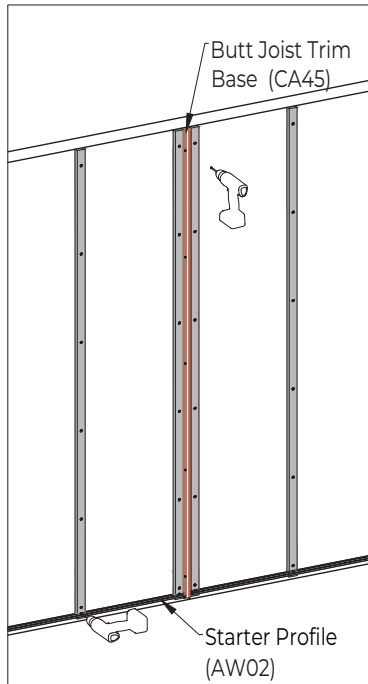
**Diagram 7.1**



**Detail 7.1**

7.2

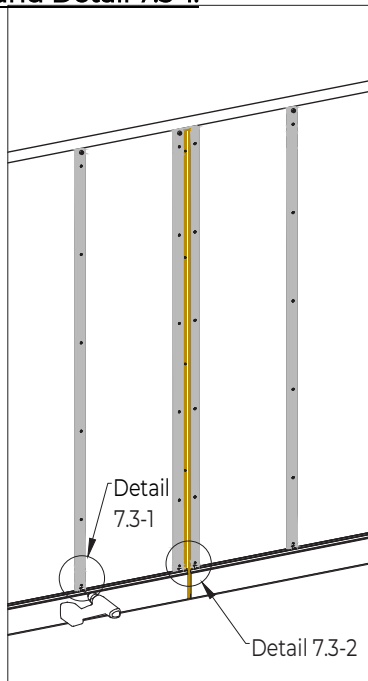
Install the Starter Profile (AW02) at the bottom screws, and the Butt Joist Trim Base (CA45), with the battens against the floor, as shown in **Diagram 7.2**.



**Diagram 7.2**

7.3

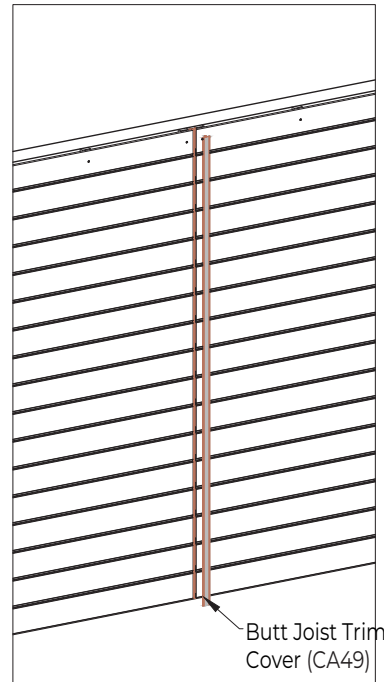
Put the first Cladding Board (US31) over the Starter Profile (AW02) and fixed it onto the batten with Clip (AW08), as shown in **Diagram 7.3** and **Detail 7.3-1**.



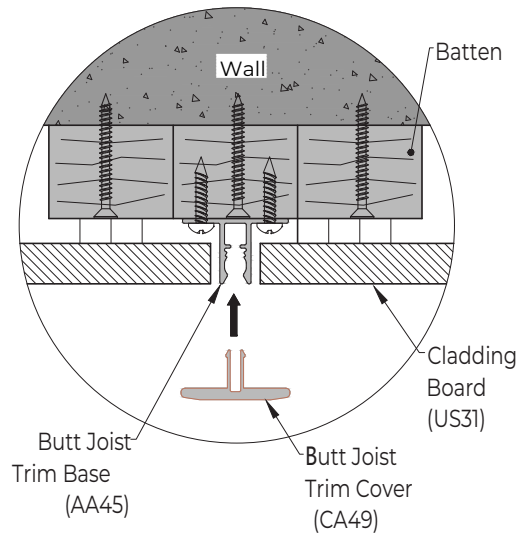
**Diagram 7.3**

7.4

Install the rest Cladding Boards, and put the Butt Joist Cover Trim (CA49) against the Trim Base (AA45), as shown in **Diagram 7.4**.



**Diagram 7.4**

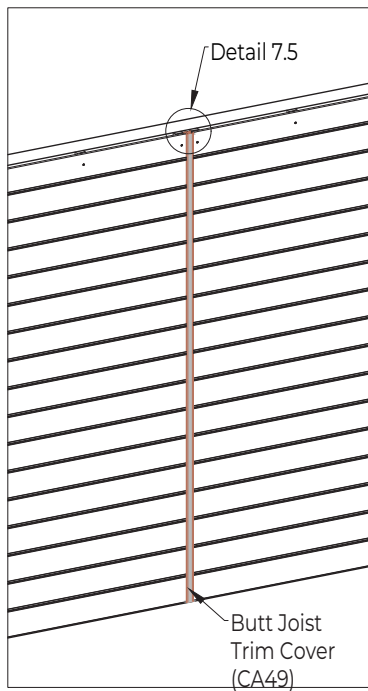


**Detail 7.4**

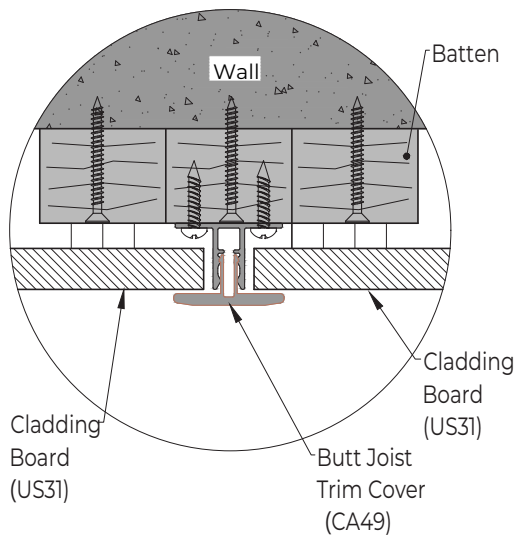


7.5

Use a rubber mallet to hammer the Butt Joist Trim Base (AA45) to snap with the Butt Joist Trim Cover (CA49) securely, as shown in **Diagram 7.5** and **Detail 7.5**



**Diagram 7.5**



**Detail 7.5**

# Wall Cladding-Vertical Installation

## Installation Procedure

Step 1: Framing - Measure and Chalk the Battens

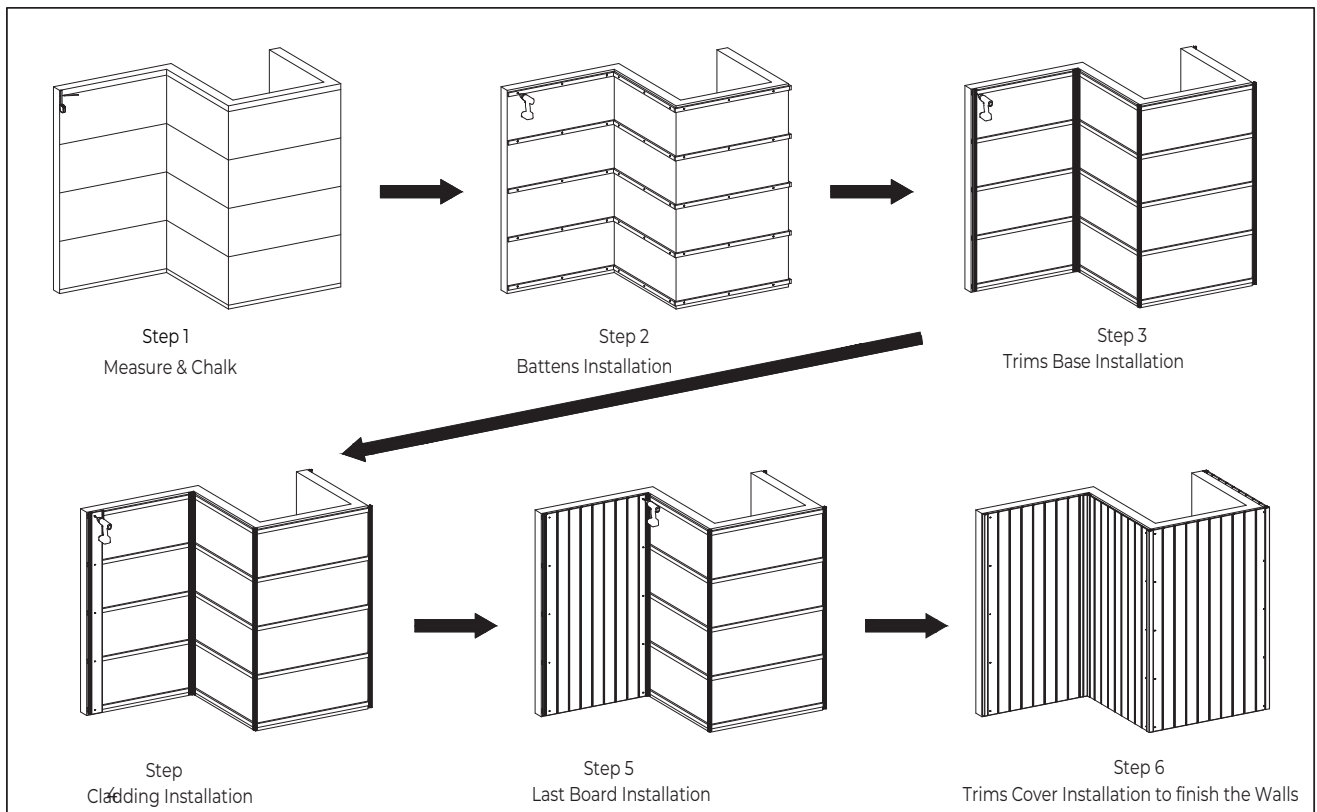
Step 2: Framing - Battens Installation

Step 3: Install the Aluminum Trim Bases

Step 4: Install the Cladding Boards

Step 5: Install the last Boards

Step 6: Install the Capped Aluminum Trim Covers to Finish the Walls.



## 1.1 Framing

The frame needs to be level before installing the cladding boards. **Diagram 1.1** shows the wall replicating different scenarios potentially occurring when installing the cladding boards.

### Wall Side A:

Cladding between the Outermost Edge to the Inside Corner.

Use the End Trim (Base AA44 and Cover CA48) and the Inside Corner Trim (Base AA46 and Cover CA50).

### Wall Side B:

Cladding between the Inside Corner to the Outside Corner.

Use the Inside Corner Trim (Base AA46 and Cover CA50) and the Outside Corner Trim (Base AA47 and Cover CA51).

### Wall Side C:

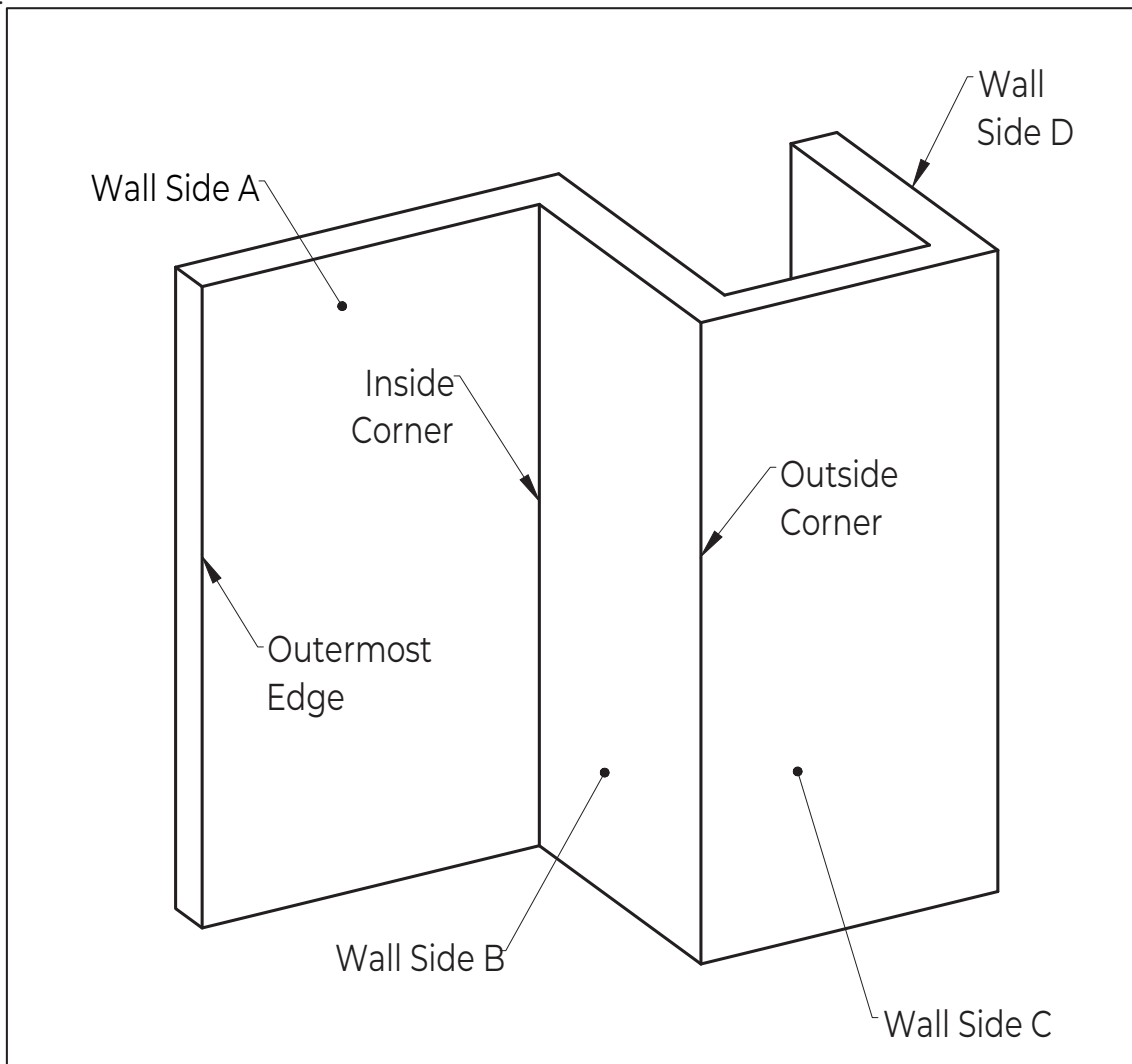
Cladding between two Outside Corner.

Use the Outside Corner Trim (Base AA47 and Cover CA51)

### Wall Side D:

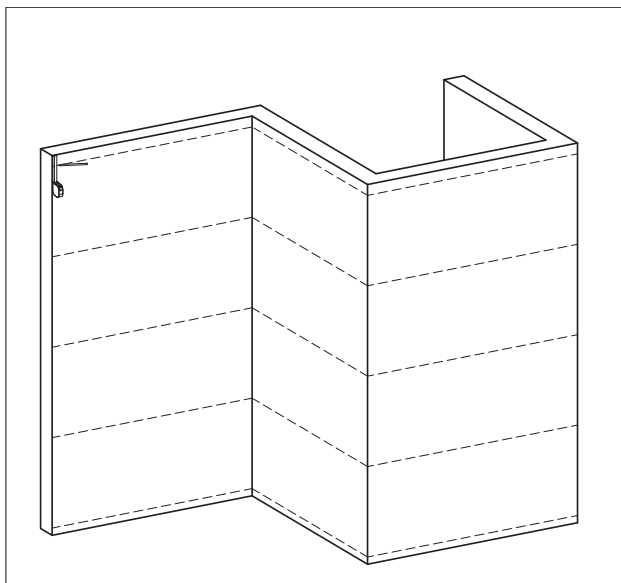
Cladding between the Outside Corner and the Outermost Edge,

Use the Outside Corner trim (Base AA47 and Cover CA51) and the End Trim (Base AA44 and Cover CA48).



**Diagram 1.1**

- 1.2** Measure and chalk the battens according to the span data specified on [Page 11](#) of this installation guide, as shown in [Diagram 1.2](#).



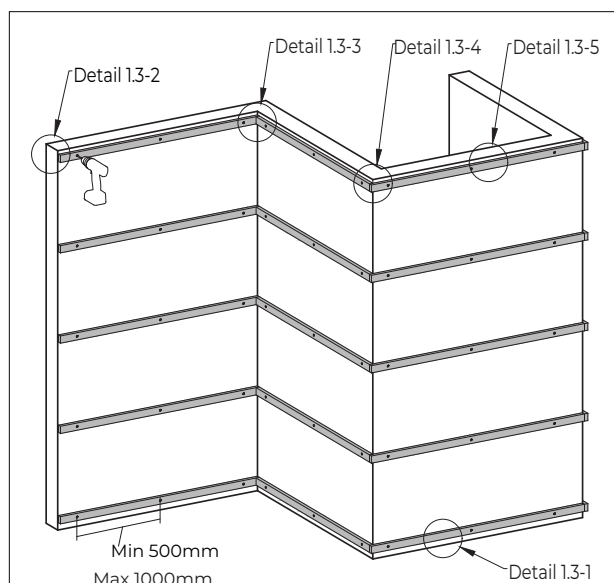
**Diagram 1.2**

**Please Note:**

1. We are using timber battens for this installation. If you are using metal/aluminum batten, please refer to [page 9](#) of this installation guide for the correct recommended screws.

2. An adequate span between the battens is required to keep the Cladding Boards from bending. Please review [page 11](#) of this installation guide to see what span is needed.

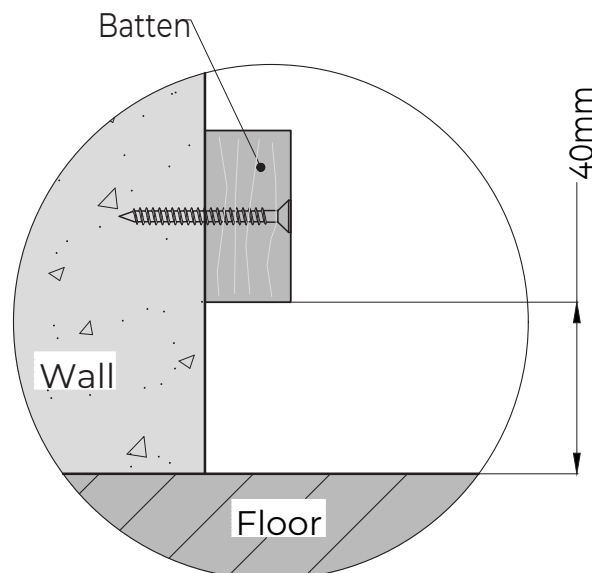
- 1.3** Fix the battens onto the wall that you intend to install with screws in the distance at least 500mm and max to 1000mm on center, as shown in [Diagram 1.3](#).



**Diagram 1.3**

**Please Note:**

1. A minimum gap of 40mm needs to be left between the batten and the floor, as shown in [Detail 1.3-1](#).

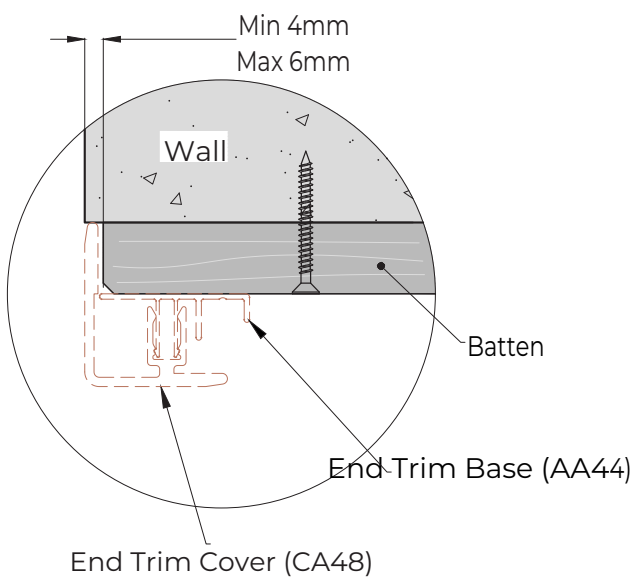


**Detail 1.3-1**

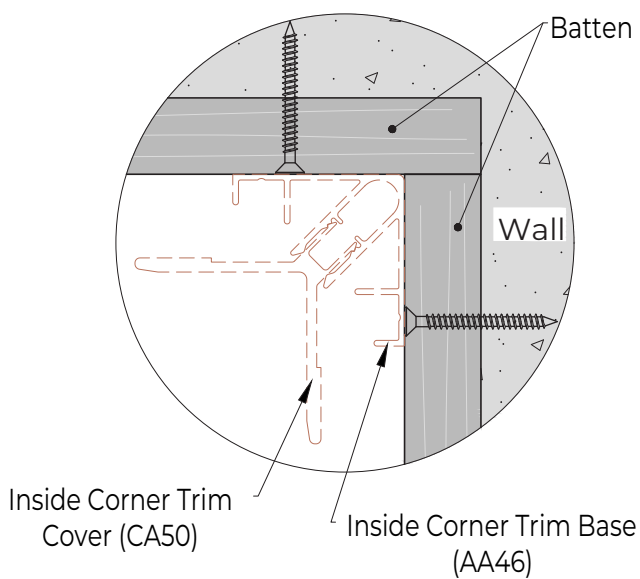
## 1.3 Continued

**Please Note:**

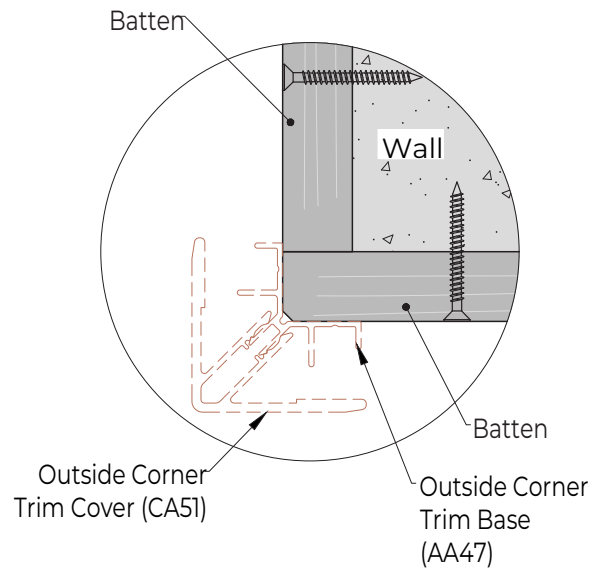
1. For the Outermost Edge, please install according to **Detail 1.3-2**.
2. For the Inside Corner, please install according to **Detail 1.3-3**.
3. For the Outside Corner, please install according to **Detail 1.3-4**.



**Detail 1.3-2**



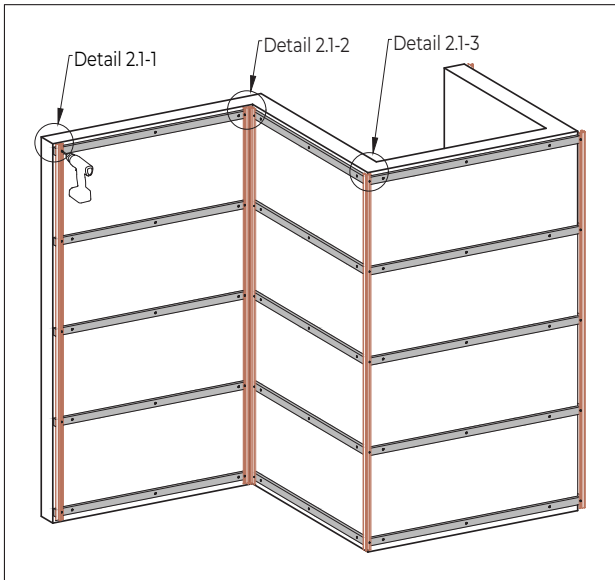
**Detail 1.3-3**



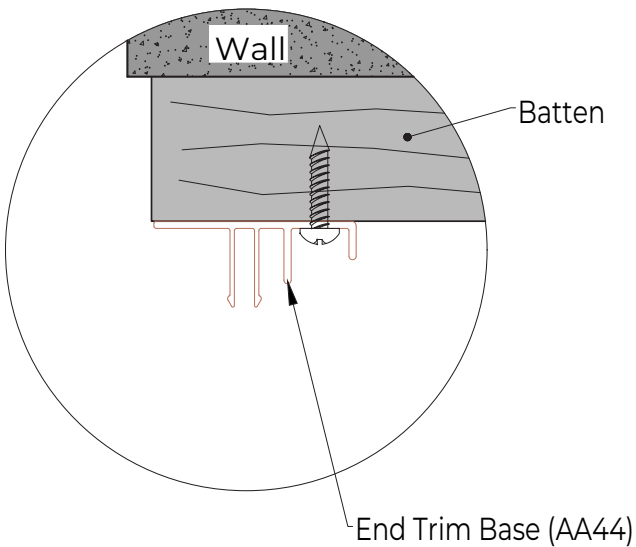
**Detail 1.3-4**

## 2.1 Install the Trim Bases

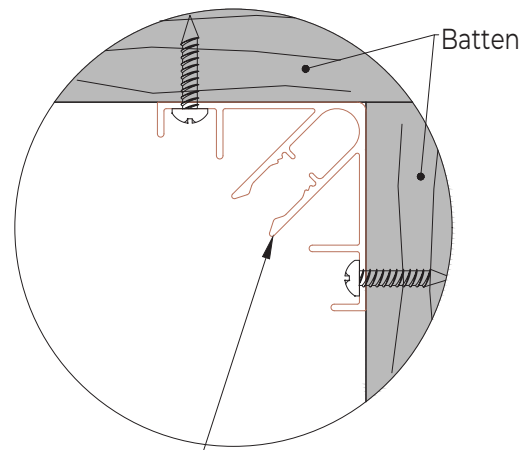
Fix the trim bases onto the Inside Corners, Outside Corners and the Outermost Edges with screws in the distance at least 500 mm and max 1000 mm, as shown in **Diagram 2.1**, **Detail 2.1-1**, **Detail 2.1-2**, and **Detail 2.1-3**.



**Diagram 2.1**

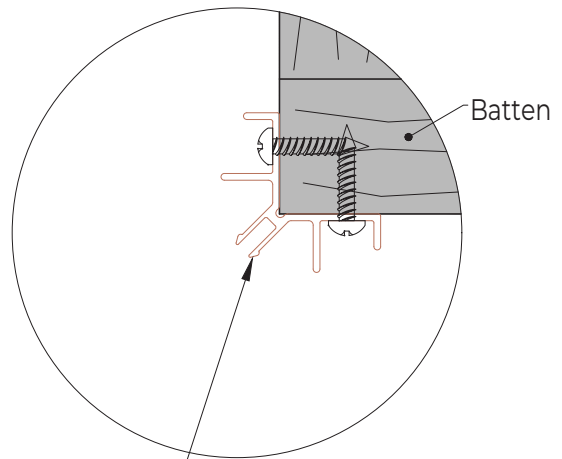


**Detail 2.1-1**



**Inside Corner Trim Base (AA46)**

**Detail 2.1-2**

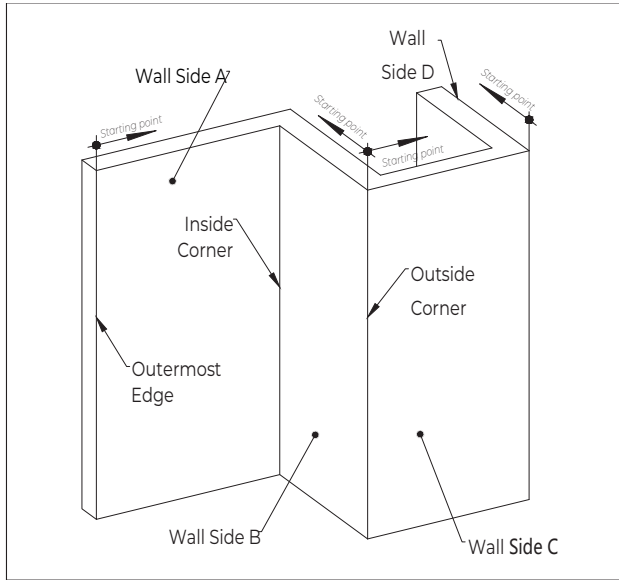


**Outside Corner Trim Base (AA47)**

**Detail 2.1-3**

# Install the First Board

**3.1** Install the First Cladding Board on the starting point, as shown in **Diagram 3.1**.

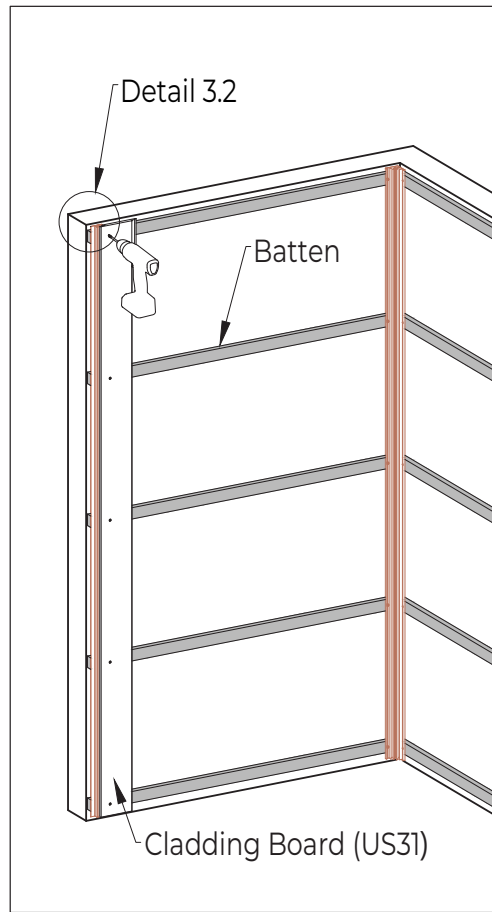


**Diagram 3.1**

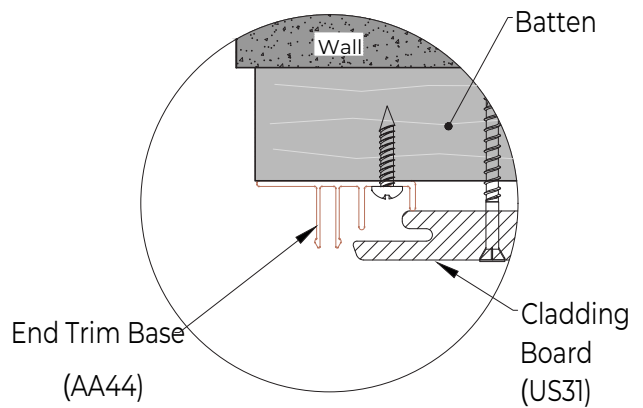
**Please Note:**

- 1. Wall Side A:** Cladding between the Outermost Edge and the Inside Corner.
  - Start the installation from the Outermost Edge.
- 2. Wall Side B:** Cladding between the Inside Corner and the Outside Corner.
  - Start the installation from the Outside Corner.
- 3. Wall Side C:** Cladding between two Outside Corners,
  - Start the installation from the Outside Corner.
- 4. Wall Side D:** Cladding between the Outside Corner and the Outermost Edge.
  - Start the installation from the Outside Corner.

**3.2** Install the First Cladding Board from the Outermost Edge, as shown in **Diagram 3.2**.



**Diagram 3.2**



**Detail 3.2**

3.3.

Lock the Cladding Board at the top, as shown in Diagram 3.3.

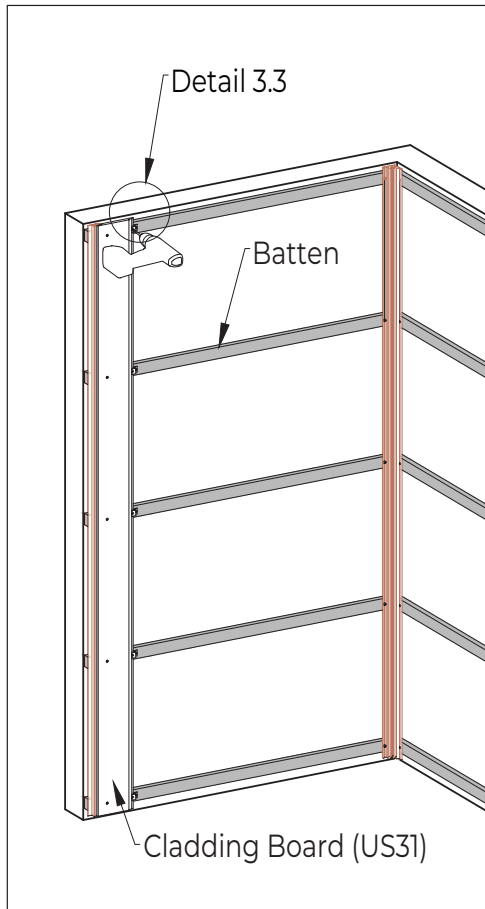


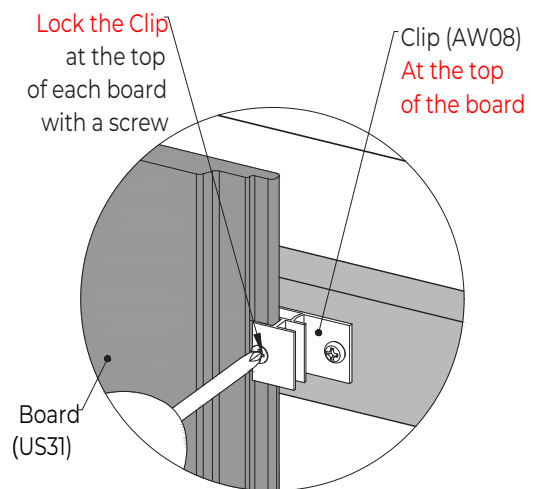
Diagram 3.3

Please Note:

Since the composite wood must allow for expansion and contraction due to temperature change, the board must be **locked at one fixed point but only one point** to allow the remaining board to move freely. When installing vertically, it is required to **lock the Clip (AW08) at the top of each board**, as shown in Detail 3.3.

**DO NOT LOCK** any other Clip (AW08) for the same board.

Please review page 12, “**Locking the Wall Cladding Board**” of this installation guide for further information.

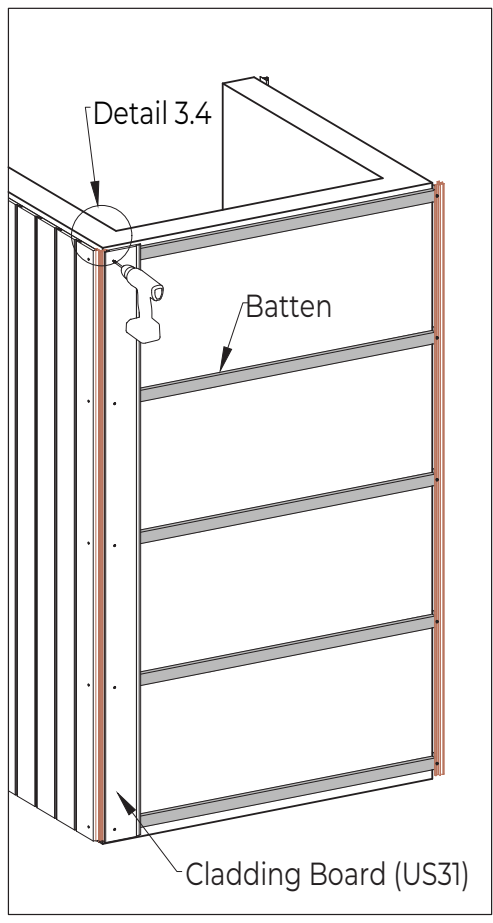


**ONLY ONE LOCKING SCREW TO BE USED PER BOARD**

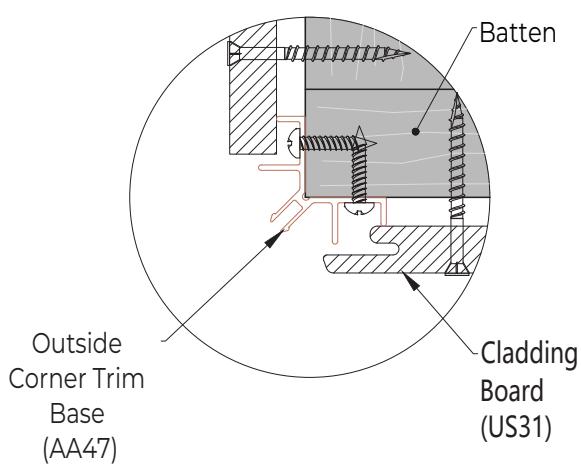
Detail 3.3



**3.4** Install the First Cladding Board from the Outside Corner, as shown in **Diagram 3.4, Detail 3.4.**



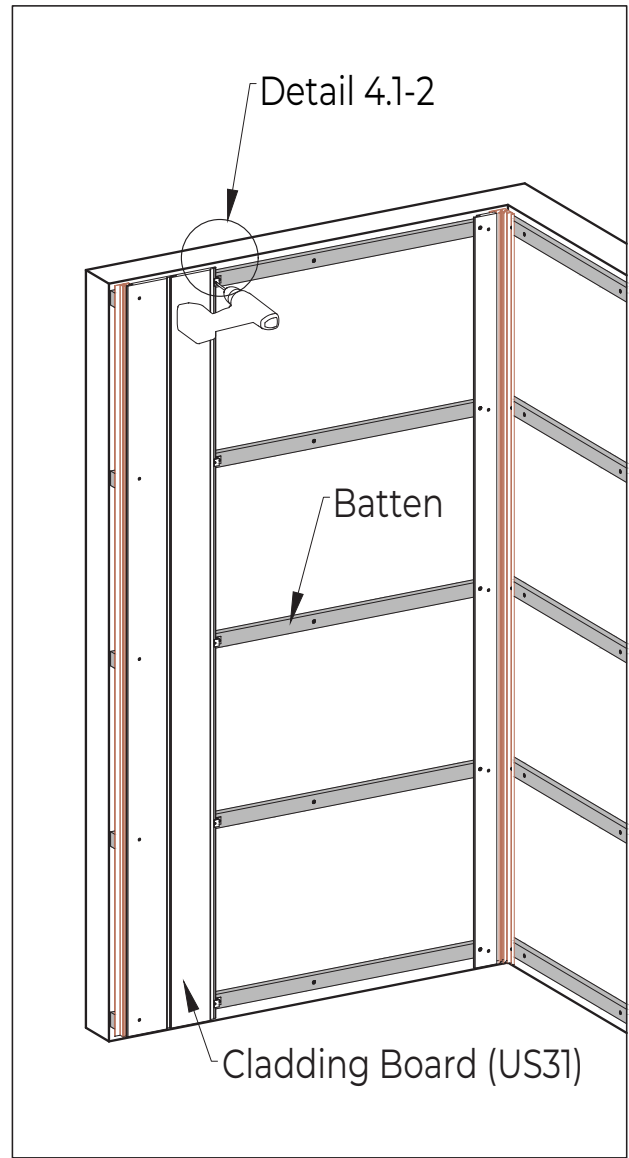
**Diagram 3.4**



**Detail 3.4**

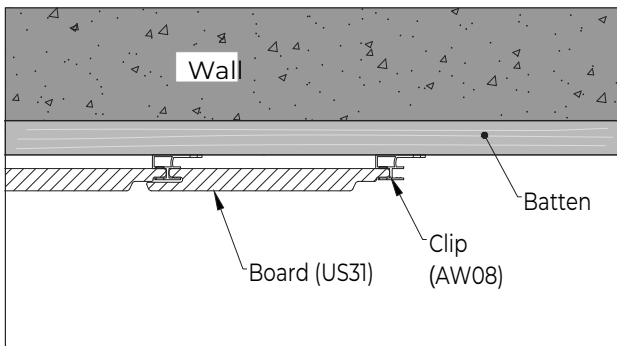
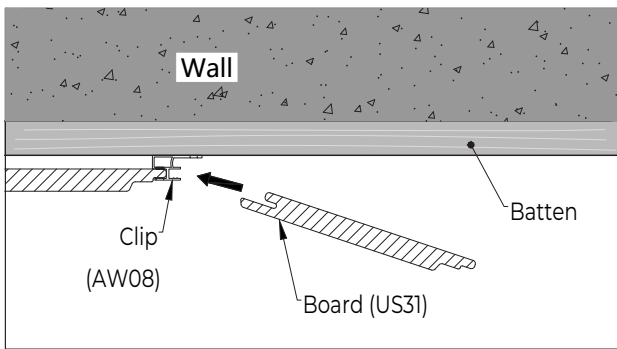
## Install the Second Board

**4.1** Put the second Cladding Board (US31) in place, and fasten it to the batten with the Clip (AW08), as shown in **Diagram 4.1, Detail 4.1-1** and **Detail 4.1-2.**

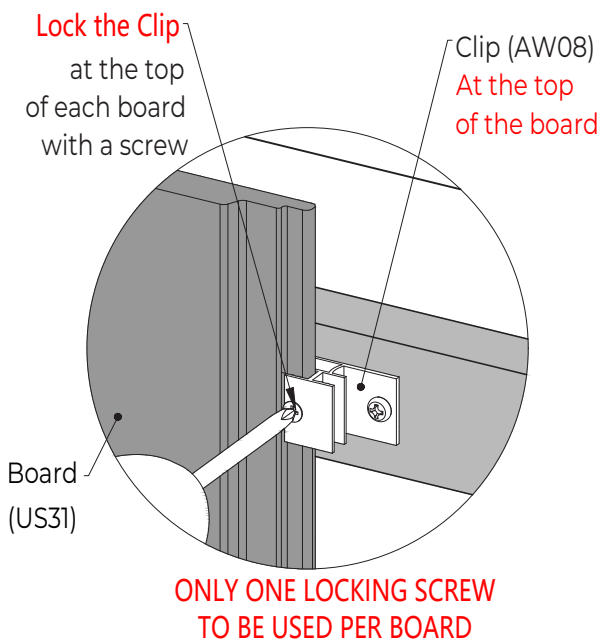


**Diagram 4.1**

## 4.1 Continued



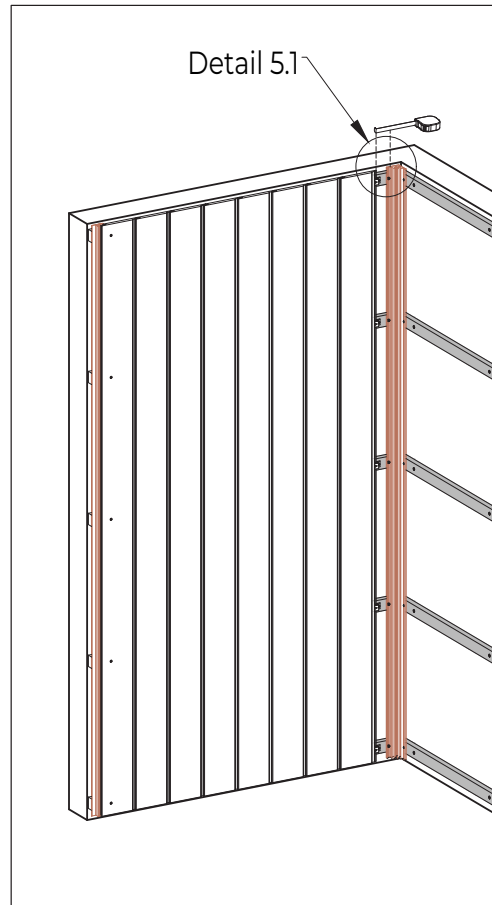
**Detail 4.1-1**



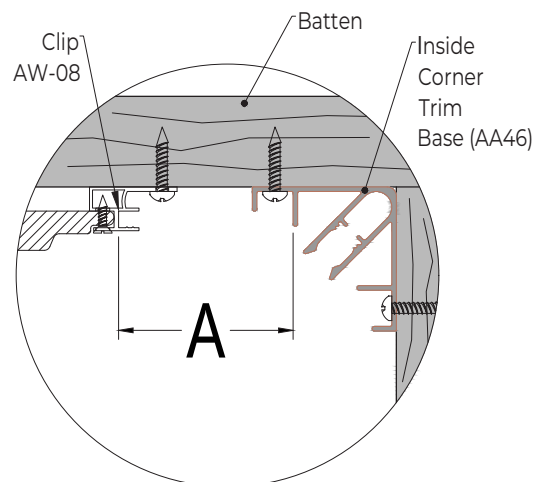
**Detail 4.1-2**

## Install the Last Board

- 5.1** When you are at the last board, measure the distance to obtain the appropriate last board's ripping dimension. Measure the last board at the **Inside Corner**, as shown in **Diagram 5.1** and **Detail 5.1**.



**Diagram 5.1**



**Detail 5.1**

Measure the last board at the Outside Corner, 5.2 as shown in Diagram 5.2 and Detail 5.2

5.2.

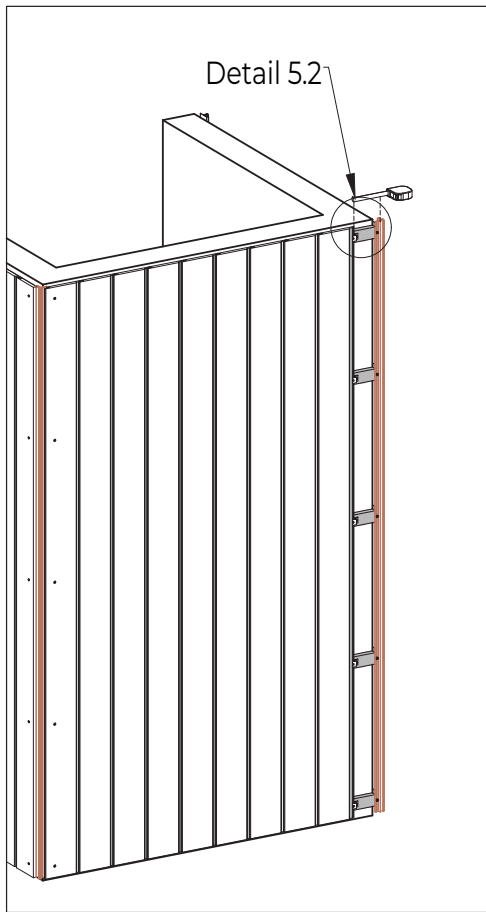
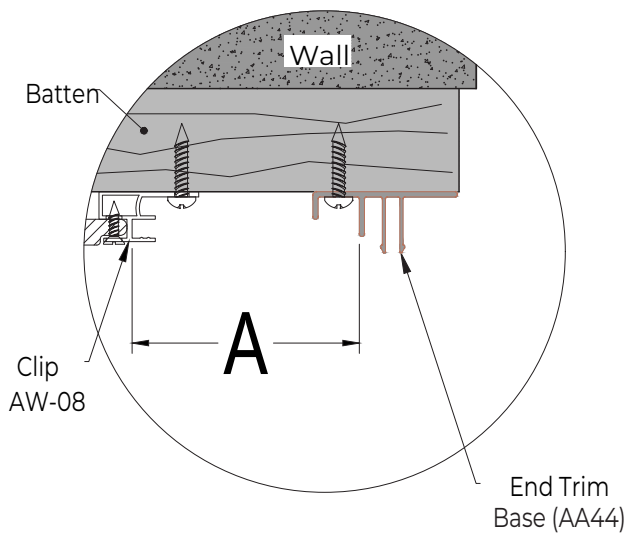


Diagram 5.2



Detail 5.2

Measure the last board at the Outermost Edge, as shown in Diagram 5.3 and Detail 5.3.

5.3.

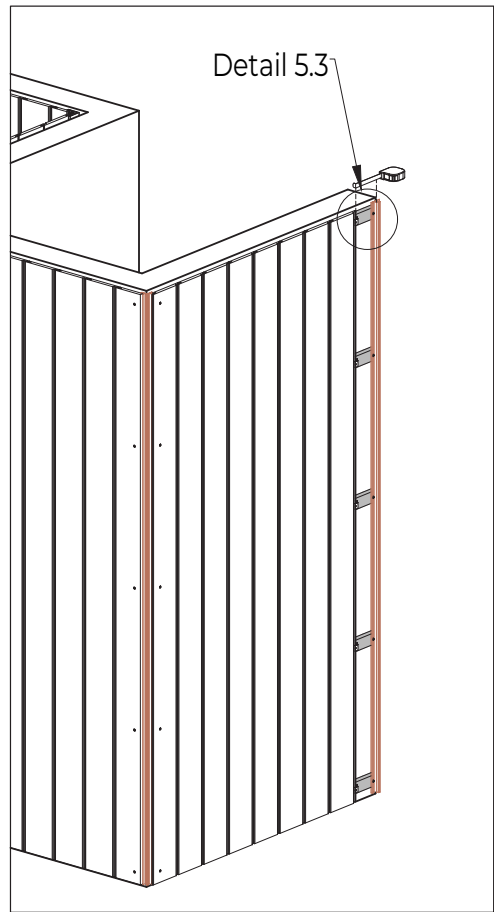
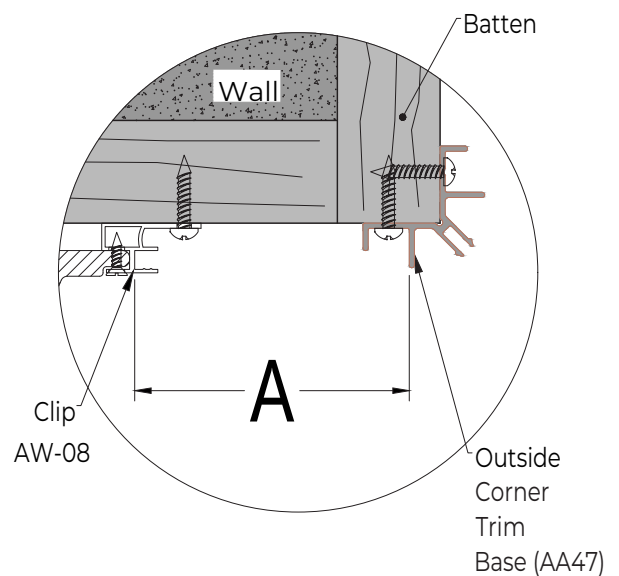


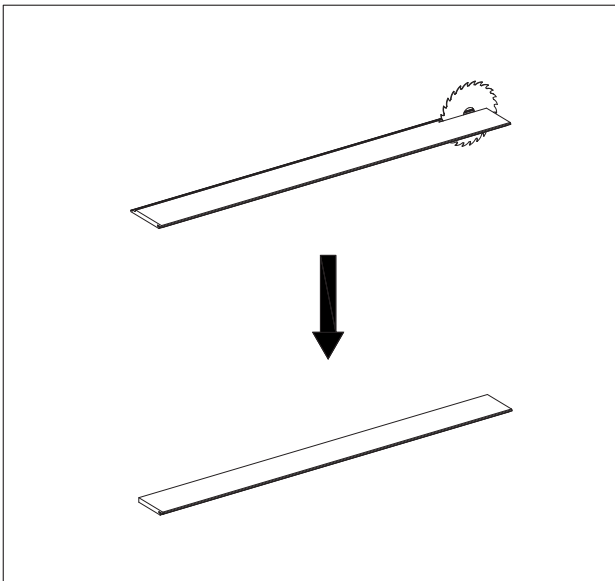
Diagram 5.3



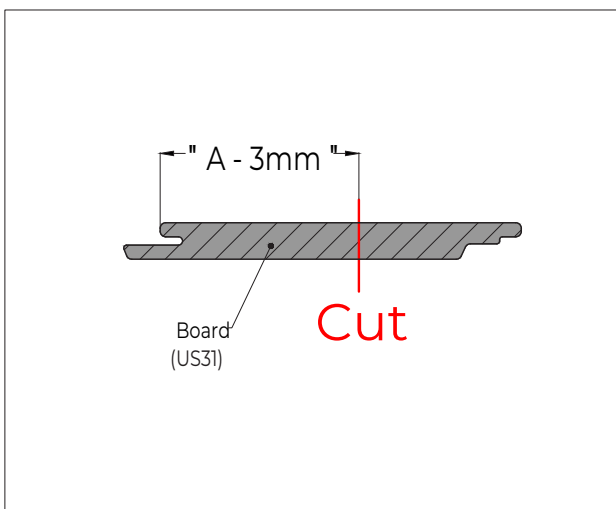
Detail 5.3

5.4

Rip the board according to the measurement, as shown in **Diagram 5.4** and **Detail 5.4**.



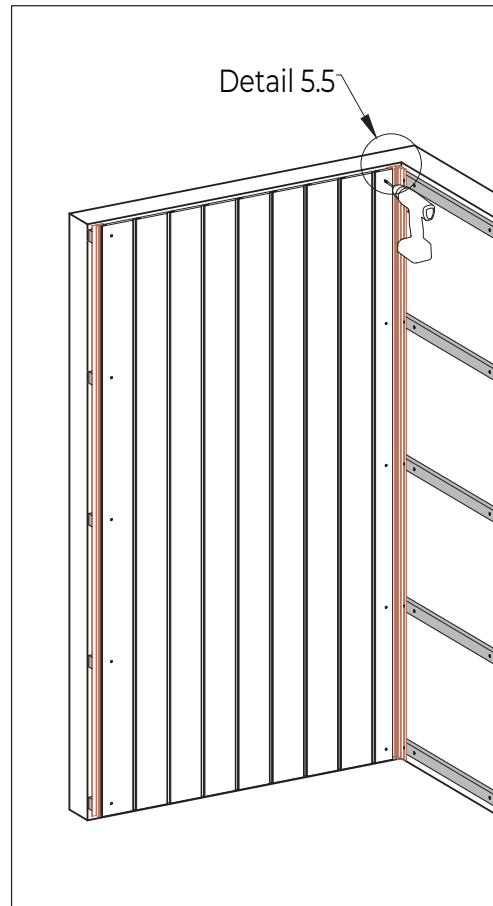
**Diagram 5.4**



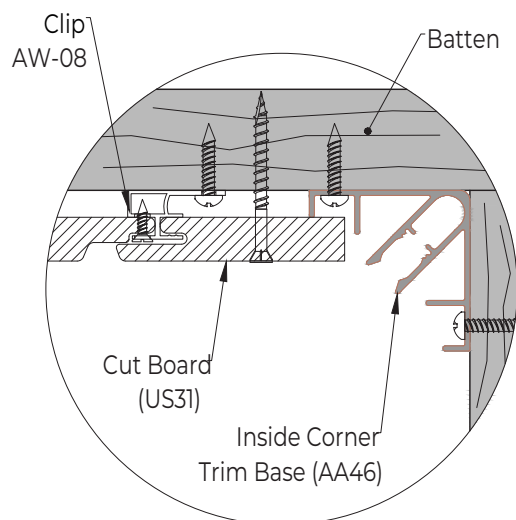
**Detail 5.4**

5.5

Put the ripped cladding board in place. Then face fix the ripped cladding board onto the batten with screws. Install the last board at the **Inside Corner**, as shown in **Diagram 5.5** and **Detail 5.5**.



**Diagram 5.5**



**Detail 5.5**

5.6

Install the last board at the Outside Corner, as shown in **Diagram 5.6** and **Detail 5.6**.

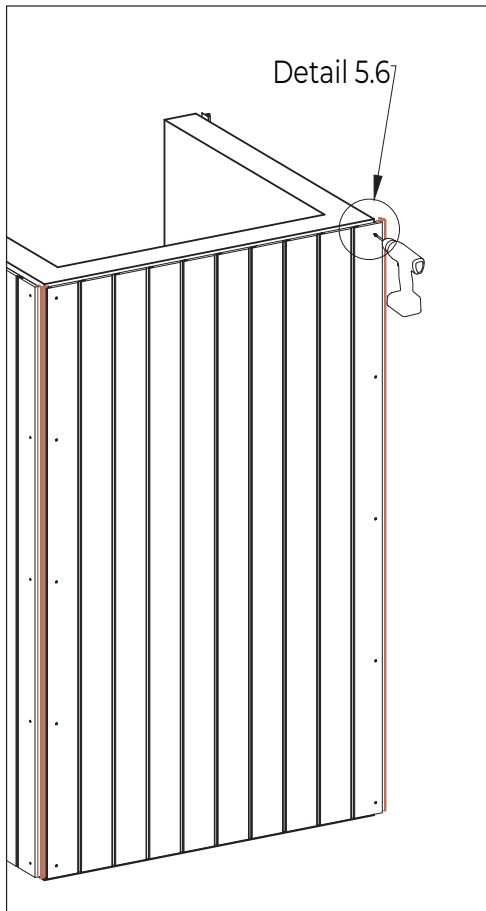
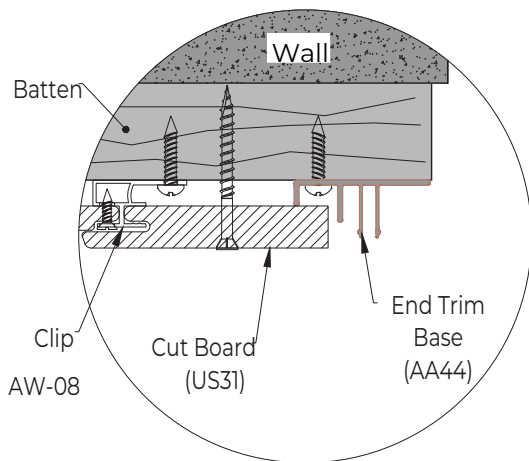


Diagram 5.6



Detail 5.6

5.7

Install the last board at the Outermost Edge, as shown in **Diagram 5.6** and **Detail 5.6**.

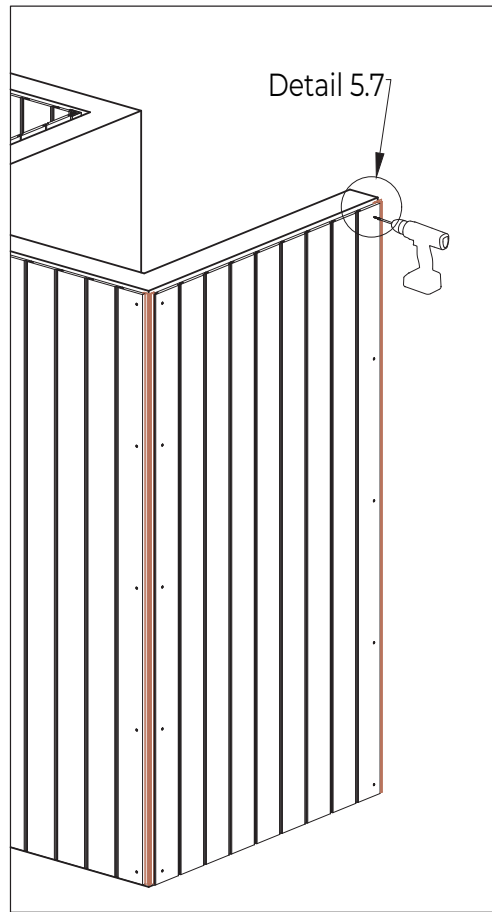
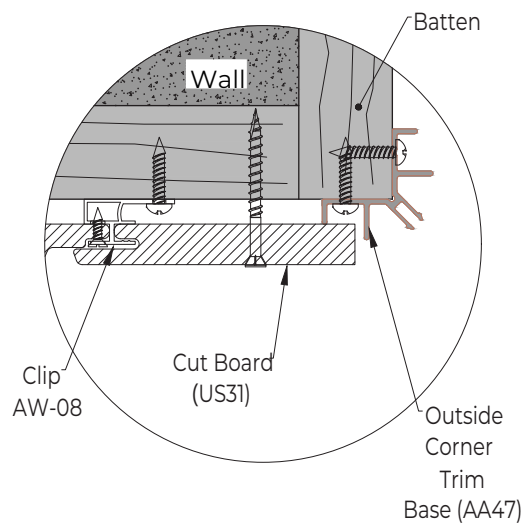


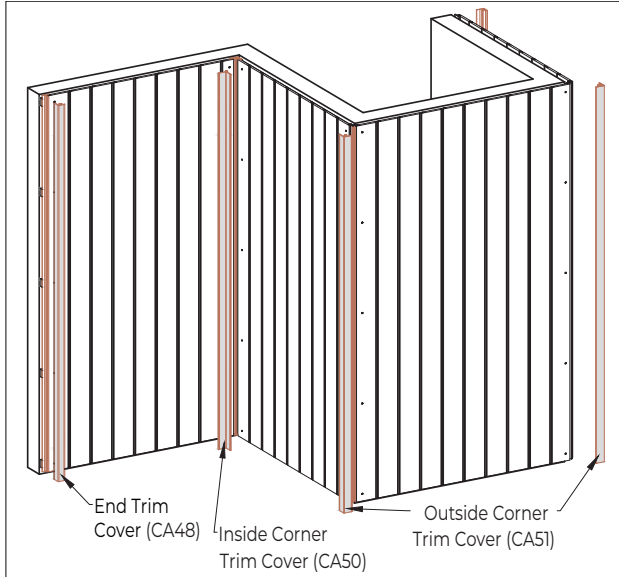
Diagram 5.7



Detail 5.7

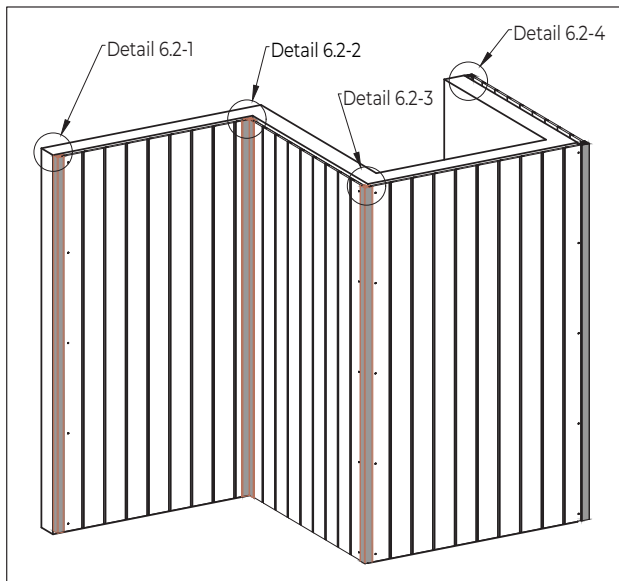
# Install the Trim Covers to Finish the Walls

**6.1** Put the trim covers against the trim bases, as shown in Diagram 6.1

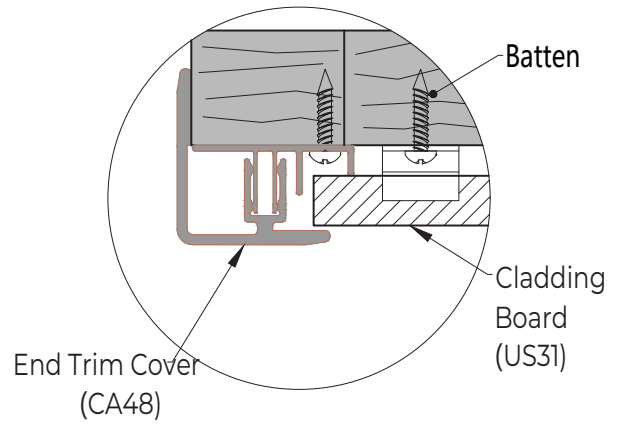


**Diagram 6.1**

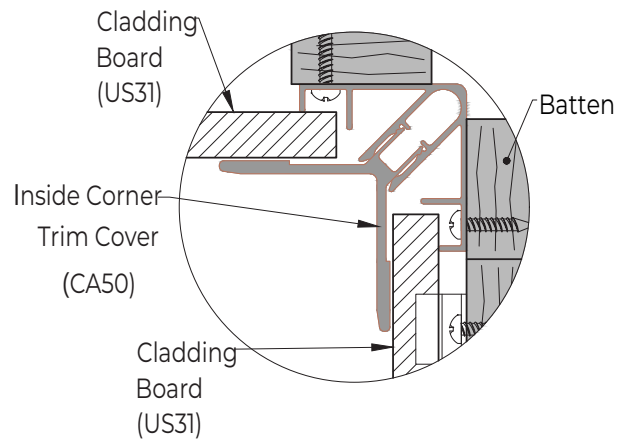
**6.2** Use a rubber mallet to hammer the covers to snap with the base securely, as shown in Diagram 6.2, Detail 6.2-1, Detail 6.2-2, and Detail 6.2-3.



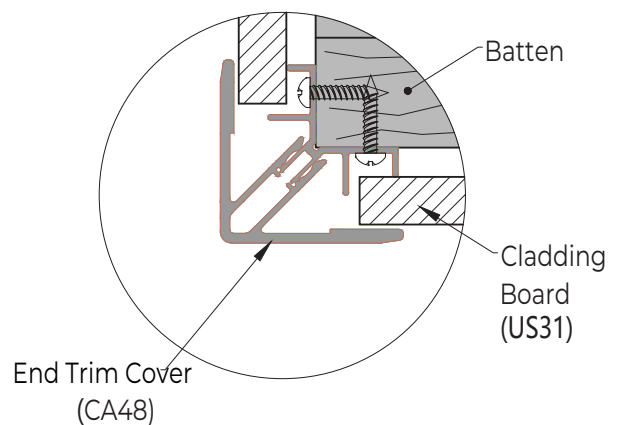
**Diagram 6.2**



**Detail 6.2-1**



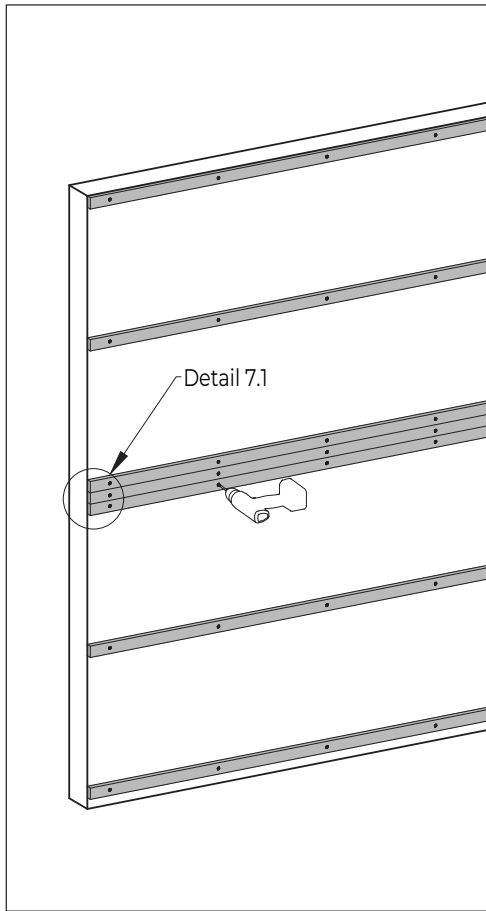
**Detail 6.2-2**



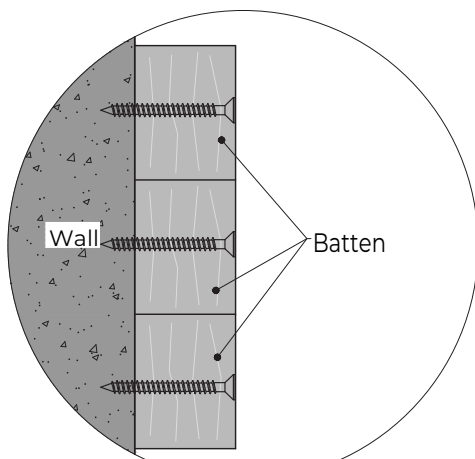
**Detail 6.2-3**

# Butt Joist Installation

**7.1** Fix the battens onto the wall with screws, as shown in **Diagram 7.1**

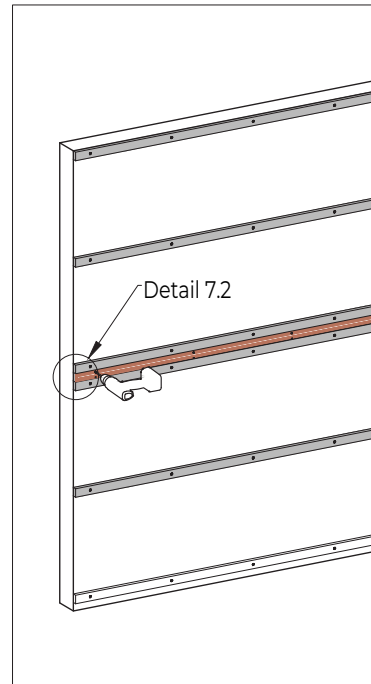


**Diagram 7.1**



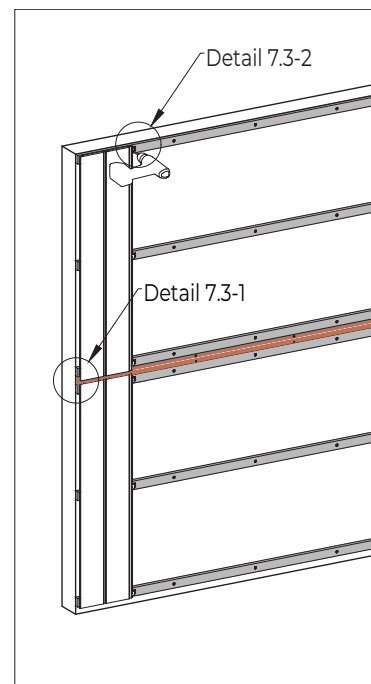
**Detail 7.1**

**7.2** Install the Butt Joist Trim Base (CA45) onto the batten with screws, as shown in **Diagram 7.2**



**Diagram 7.2**

**7.3** Put the Cladding Boards (US31) in place and fixed it onto the batten with the Clip (AW08), as shown in **Diagram 7.3** and **Detail 7.3-1**.



**Diagram 7.3**

7.4

Install the rest Cladding Boards, and put the Butt Joist Trim Cover(CA49) against the Butt Joist Trim Base(AA45), as shown in Diagram 7.4.

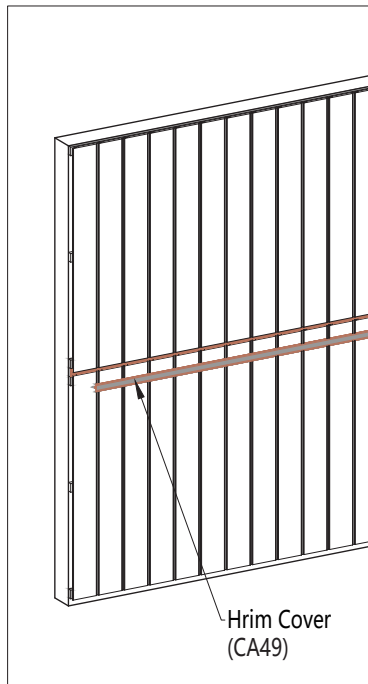
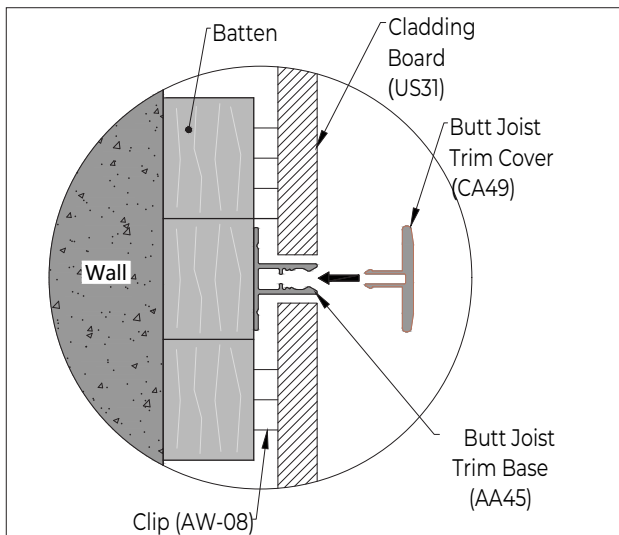


Diagram 7.4



Detail 7.4

7.5

Use a rubber mallet to hammer the Butt Joist Cover Trim(CA49) to a Butt Joist Trim Base (AA45) securely, as shown in Diagram 7.5 and Detail 7.5.

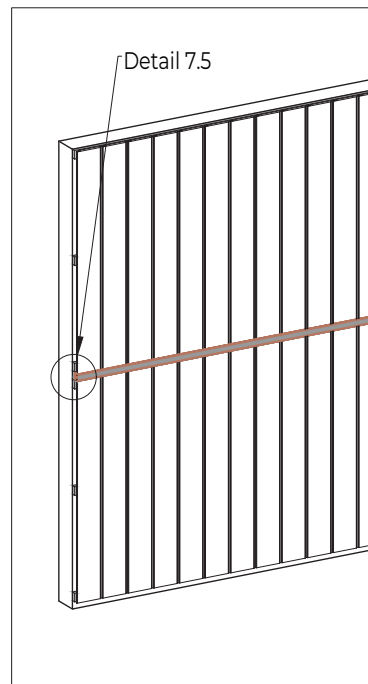
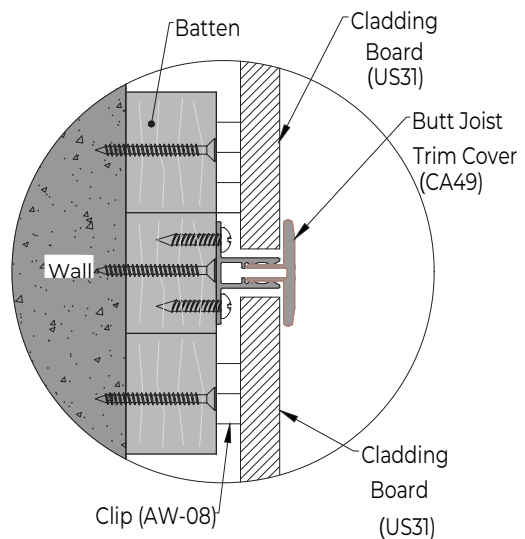


Diagram 7.5



Detail 7.5





# Wall Cladding Installation Guide

v05 AUS

©2024 NewTechWood Corporation

NewTechWood® is a registered trademark of NewTechWood Corporation. To obtain a copy of the most current version of this installation guide, visit us online at [www.newtechwood.com.au](http://www.newtechwood.com.au)

